



Roto-Bin-Dicator® PRO Installation & Operation Manual



Roto-Bin-Dicator® PRO

Installation & Operation Manual

CONTENTS

I.	HANDLING & STORAGE.....	1
	Inspection and Handling	
	Disposal and Recycling	
	Storage	
II.	GENERAL SAFETY.....	2
	Authorized Personnel	
	Use	
	Misuse	
III.	PRODUCT DESCRIPTION	3
	Technical Specifications	
	Approvals	
IV.	MECHANICAL INSTALLATION	4
	Guidelines	
	Figure 1. Mounting in Relation to Flow of Material	
	Mounting Considerations	
	Installation	
	Figure 2. Mounting Plate & Gasket Diagram	
V.	ELECTRICAL INSTALLATION.....	6
	General Safety	
	Disconnect Requirements for Permanently Installed Equipment	
	Protective Earth Ground	
	Conduit Cable Connection	
	Electrical Connections	
	Figure 3. Power and Ground Connections	
	Figure 4. Main Relay Connections	
	Figure 5. Auxiliary Relay Connections	
	Figure 6. Wiring & Fail Safe	
	Figure 7. Enclosure with Cover Removed	
VI.	SET-UP	11
	Operation	
	Product Overview	
	Figure 8. Dip Switches	
	Time Delay Settings	
	Fault Option	
	Pause Mode	
	Sensitivity Settings	

VII. MAINTENANCE 15
VIII. TROUBLESHOOTING 17

SAFETY SYMBOLS



WARNING:

IDENTIFIES CONDITIONS OR PROCEDURES, WHICH IF NOT FOLLOWED, COULD RESULT IN SERIOUS INJURY. RISK OF ELECTRICAL SHOCK.



CAUTION:

IDENTIFIES CONDITIONS OR PROCEDURES, WHICH IF NOT FOLLOWED, COULD RESULT IN SERIOUS DAMAGE OR FAILURE OF THE EQUIPMENT.

Roto-Bin-Dicator PRO Installation & Operation Manual

I. HANDLING AND STORAGE

SAVE THESE INSTRUCTIONS

INSPECTION AND HANDLING

Do not dispose of the carton or packing materials.

Each package should be inspected upon receipt for damage that may have occurred due to mishandling during shipping. If the unit is received damaged, notify the carrier or the factory for instructions. Failure to do so may void your warranty. If you have any problems or questions, consult Customer Support at 800-778-9242.

DISPOSAL AND RECYCLING

This product can be recycled by specialized companies and must not be disposed of in a municipal collection site. If you do not have the means to dispose of properly, please contact for return and disposal instructions or options.

STORAGE

If the device is not scheduled for immediate installation following delivery, the following steps should be observed:

1. Following inspection, repackage the unit into its original packaging.
2. Select a clean dry site, free of vibration, shock and impact hazards.
3. If storage will be extended longer than 30 days, the unit must be stored at temperatures between 32° and 158° F (0° to 70° C) in non-condensing atmosphere with humidity less than 85%.



CAUTION: DO NOT LEAVE AN UN-POWERED UNIT OUTDOORS FOR A PROLONGED PERIOD.

II. GENERAL SAFETY



WARNING: ONLY CERTAIN MODELS CAN BE USED IN HAZARDOUS LOCATIONS; SEE NAMEPLATE.

SOME MODELS SHALL ONLY BE USED IN APPLICATIONS COVERED BY THE STATED RATINGS OR NON-HAZARDOUS LOCATIONS.

AUTHORIZED PERSONNEL

All instructions described in the document must be performed by authorized and qualified service personnel only. Before installing the unit, please read these instructions and familiarize yourself with the requirements and functions of the device. The required personal protective equipment must always be worn when servicing this device.

USE

The device is solely intended for use as described in this manual. Reliable operation is ensured only if the instrument is used according to the specifications described in this document. For safety and warranty reasons, use of accessory equipment not recommended by the manufacturer or modification of this device is explicitly forbidden. All servicing of this equipment must be performed by qualified service personnel only. This device should be mounted in locations where it will not be subject to tampering by unauthorized personnel.

MISUSE

Improper use or installation of this device may cause the following:

- Personal injury or harm
- Application specific hazards such as vessel overfill
- Damage to the device or system

If any questions or problems arise during installation of this equipment, please contact Customer Support at 800-778-9242.

III. PRODUCT DESCRIPTION

TECHNICAL SPECIFICATIONS

FUNCTIONAL	
Operating Power	Universal, 120 - 240 VAC 50/60 Hz or 24 - 48 VDC
Power Consumption	3 watts (1.8 watts in Pause Mode)
Ambient Temperature	Ordinary Location: -40° to 158°F (-40° to 70°C) Hazardous Location: -4° to 140°F (-20° to 60°C) Hazardous Location, Extended: -40° to 140°F (-40° to 60°C)
Process Temperature	-20° to 302°F (-29° to 150°C) Standard Up to 500°F (260°C) with Extension 3 and Lag
Outputs	Main Relay: 8 A DPDT @ 240 VAC or 30 VDC (resistive) Auxiliary Relay: 0.46 A SPDT @ 150 VAC or 1 A @ 30 VDC
PERFORMANCE	
Time Delay	Field Selectable; Up to 25 seconds
Fail Safe	Field Selectable; high/low level
Sensitivity	Minimum; 3.4 lbs/ft ³ (54 kg/m ³), Field Adjustable; Paddle dependent
Diagnostics	LED Indicators with blink codes; see Troubleshooting section
PHYSICAL	
Enclosure Material	Aluminum, Epoxy Coated Aluminum, Stainless Steel or Nickel Plated Aluminum
Dual Conduit Entry	3/4" NPT or M20 x 1.5
Mounting Plate Material	Mild Steel or 304 Stainless Steel
Rigid Shaft and Paddle	Metal parts of all designs are 316 stainless steel
Flex Shaft	Available in neoprene, 155°F (68°C) or silicone, 400° F (204°C) coatings
Shipping Weight	Aluminum housing: Approximately 10 lbs (4.5 kg) Stainless steel housing 16 lbs (7.3 kg)
Pollution Degree	2
Installation Category	II
Altitude	6,562 ft (2,000 m)

APPROVALS AND RATINGS

UL (US and Canada):

- Ordinary Location Type 4X; IP66
- Hazardous Location, Type 4X
- Explosion Proof
- Dust Ignition Proof

ATEX/IEC/IECex: (Pending)

- Dust and Gas Categories; IP66

CE

- Electromagnetic Compatibility Directive
- Low Voltage Directive

IV. MECHANICAL INSTALLATION



WARNING: REMOVE POWER FROM THE UNIT BEFORE INSTALLING, REMOVING, OR MAKING ADJUSTMENTS.



WARNING: IN ORDER TO MAINTAIN SAFE OPERATION IN HAZARDOUS LOCATIONS, THE INTEGRITY OF THE ALUMINUM CASTING AND THE EPDM SEALS MUST BE MAINTAINED. THE USER/INSTALLER MUST AVOID INSTALLATIONS WHERE AGGRESSIVE SUBSTANCES MAY BE PRESENT AND COULD AFFECT THE PERFORMANCE OF THESE MATERIALS. CARE MUST BE EXERCISED WHEN REMOVING AND REPLACING THE COVER, SO NO MARRING, SCRATCHING OR DAMAGE OCCURS TO THE FLANGES.



WARNING: FOR UNITS INSTALLED IN HAZAROUS LOCATIONS, TO REDUCE THE RISK OF IGNITION OF HAZARDOUS ATMOSPHERES, CONDUIT RUNS MUST HAVE A SEALING FITTING CONNECTING WITHIN 18 IN. OF THE ENCLOSURE.



WARNING: FOR PRODUCTS MARKED AS TYPE 4X, USE TYPE 4X HUB FITTING; FOR IP66 USE IP66 HUB FITTING.



CAUTION: WHEN MOUNTING UNITS, NEVER ADJUST THE ORIENTATION BY TURNING THE HOUSING. USE 2-1/4 IN. WRENCH FOR PROCESS FITTING UNITS, OTHERWISE A STRAP WRENCH SHOULD BE USED TO TIGHTEN INTO PLACE.

GUIDELINES

The following precautions should be observed when installing and operating a Roto-Bin-Dicator PRO device:

- The installation and wiring of this product must comply with all national, federal, state, municipal and local codes that apply.
- Handle carefully to prevent damage.
- Do not allow moisture to enter the electronics enclosure. Conduit should slope downward from the housing. Install drip loops (or drain fitting) and seal conduit with silicone rubber product.
- For horizontally mounted units, the conduit openings must face downward.

The unit must be located at the position where level indication is desired. The unit may be mounted through the top or side wall of the vessel. To ensure reliable operation, observe the following guidelines when choosing the mounting location.

- DO NOT mount the Roto-Bin-Dicator PRO in an area where the paddle or shaft can contact the vessel.
- DO NOT mount the Roto-Bin-Dicator PRO where the paddle or shaft are directly in the flow of material. The material should be able to flow on to and away from the paddle. If necessary, use a baffle to protect the paddle and shaft from falling material (ie. avalanche, mass flow and in-coming flow stream). The baffle should be placed 6 to 12 inches above the paddle, distance depend on paddle size. See Figure 1

Figure 1. Mounting In Relation To Flow of Material

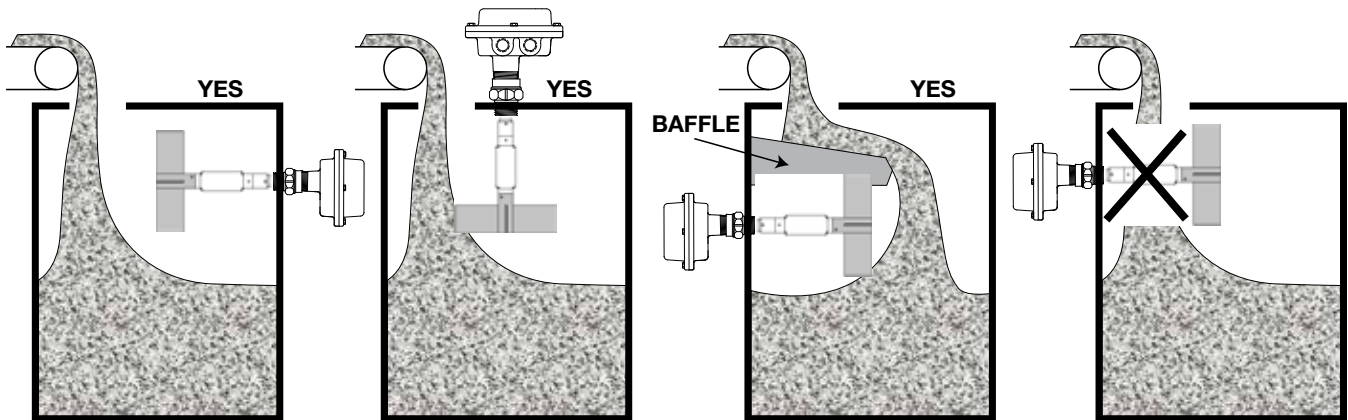

INSTALLATION FOR USE WITH MOUNTING PLATES

1. On a 7 in. bolt circle, drill and tap or drill 6 equally spaced holes in the bin wall for 1/4 in. bolts or cap screws. If not tapped, bolt heads should be tack welded to the bin inner wall. See Figure 2
2. Cut a 5 in. diameter hole to pass the paddle through. Contact factory for non-standard wall thickness greater than 1/4 in.

MOUNTING - SIDE OF BIN

1. Conduit opening must face down.
2. Assemble gasket between the mounting plate and the bin wall.
3. Flat washer, customer supplied, is recommended between mounting plate and fastening hardware.

Figure 2. Mounting Plate & Gasket Diagram

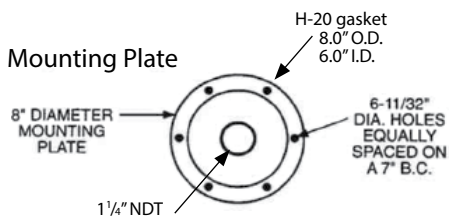

MOUNTING - TOP OF BIN

1. Assemble gasket between the mounting plate and the bin.
2. Flat washer, customer supplied, is recommended between mounting plate and fastening hardware.

NOTE: All extended units should have shaft guard and/or flex coupling.
 NOTE: Extended units with shaft lengths greater than 12 inches require a shaft guard.
 NOTE: It is recommended that the shaft guard be braced to bin wall at 6 foot intervals.

INSTALLATION FOR USE WITHOUT MOUNTING PLATES

Preferred mount is through half couplings; a full coupling will allow material to collect around the shaft, which may cause additional drag on the rotating shaft.

V. ELECTRICAL INSTALLATION



WARNING: REMOVE POWER FROM THE UNIT BEFORE INSTALLING, REMOVING, OR MAKING ADJUSTMENTS.



WARNING: FOR UNITS INSTALLED IN HAZAROUS LOCATIONS, TO REDUCE THE RISK OF IGNITION OF HAZARDOUS ATMOSPHERES, CONDUIT RUNS MUST HAVE A SEALING FITTING CONNECTING WITHIN 18 IN. OF THE ENCLOSURE.



WARNING: FOR PRODUCTS MARKED AS TYPE 4X, USE TYPE 4X HUB FITTING; FOR IP66 USE IP66 HUB FITTING.



CAUTION: IF THE UNIT WAS SUPPLIED WITH A GASKET, AVOID FOLDING, CUTTING OR TEARING THE GASKET. DAMAGING THE GASKET CAN ALLOW MOISTURE TO ENTER THE ENCLOSURE AND DAMAGER THE UNIT



CAUTION: TO REDUCE THE RISK OF IGNITION IN HAZARDOUS ATMOSPHERES, DISCONNECT THE EQUIPMENT FROM SUPPLY CURCIUT BEFORE OPENING. KEEP ASSEMBLY TIGHTLY CLOSE WHEN IN OPERATION.

GENERAL SAFETY

When using electrical equipment, you should always follow basic safety precautions, including the following:

- The installation and wiring of this product must comply with all national, federal, state, municipal, and local codes that apply.
- Properly ground the enclosure to an adequate earth ground.
- Do not modify any factory wiring. Connections should only be made to the terminals described in this section.
- All connections to the Roto-Bin-Dicator PRO must use conductors with an insulation rating of 300 V minimum, rated for 212° F (105° C), a minimum flammability rating of VW-1, and be of appropriate gauge for the voltage and current required (see Specifications).
- Do not allow moisture to enter the electronics enclosure. Conduit should slope downward from the Roto-Bin-Dicator PRO housing. Install drip loops and seal conduit with silicone rubber product. For horizontally mounted units, the conduit openings must face downward.

DISCONNECT REQUIREMENTS FOR PERMANENTLY INSTALLED EQUIPMENT

A dedicated disconnecting device (circuit breaker) must be provided for the proper installation of the unit. If independent circuits are used for power input and main relay outputs, individual disconnects are required. Disconnects must meet the following requirements:

- Located in close proximity to the device
- Easily accessible to the operator
- Appropriately marked as the disconnect for the device and associated circuit
- Sized appropriately to the requirements of the protected circuit (See Specifications)

PROTECTIVE EARTH GROUND

To eliminate shock hazards, the unit is provided with an external “earth” terminal or lead which must be connected to earth ground. In addition, the input power ground lead must be connected to the “protective earth” () terminal provided. Wire sizes must be selected such that it can safely carry the sum total of all circuits’ maximum amperage

CONDUIT CABLE CONNECTION

Two threaded female conduit openings are provided in the housing for input and output wiring. When only one conduit opening is used for installation, the unused opening must be sealed with a suitable type 4X/IP66 plug with pipe sealant in order to maintain approval requirements.

ELECTRICAL CONNECTIONS

Note: The Roto-Bin-Dicator PRO can be operated from 120-240 VAC 50/60 Hz or 24-48 VDC and provides reverse polarity protection in the event of a wiring error.

Input Power Connections

1. Refer to Figures 3 and 7 when connecting input power to the unit.
2. Loosen the housing cover screws and remove cover.

Note: Two threaded female conduit openings are provided in the housing to separate input and output wiring.

3. Pull approximately 4.5” of cable through conduit closest to the grounding bracket and strip as follows:
 - a. Ground – $\frac{3}{8}$ ” (9 to 10 mm)
 - b. Power Leads – $\frac{1}{4}$ ” (6 to 7 mm)
4. Attach incoming ground lead to grounding bracket as shown in Figure 3.

Note: The Roto-Bin-Dicator PRO incorporates pluggable terminal blocks for ease of connection. If the terminal block is unplugged while making connections, ensure it is seated properly when reinstalled.

5. Attach power leads to terminal block as shown in Figure 3 and 7.
6. Check that all wires are held tightly in place by lightly pulling each conductor.

Main Relay Connections

7. Refer to Figures 4, 6 and 7 when connecting to the main relay.
8. Pull approximately 4.5” (11.43 cm) of cable through conduit and strip $\frac{1}{4}$ ” (6 to 7 mm).
9. Attach leads to terminal block as shown in Figure 6 and 7.
10. Check that all wires are held tightly in place by lightly pulling each conductor.

Auxiliary Relay Connections

11. Refer to Figures 5 and 7 when connecting to the auxiliary relay.
12. Pull approximately 5.5” (13.97 cm) of cable through conduit and strip $\frac{1}{4}$ ” (6 to 7 mm).
13. Attach leads to terminal block as shown in Figure 7. (Continued on page 9)

14. Check that all wires are held tightly in place by lightly pulling each conductor.
15. Reinstall the gasket, if necessary.
16. Replace cover and tighten screws to 60 in-lb (6.8 n-m) of torque

Figure 3. Power and Ground Connections

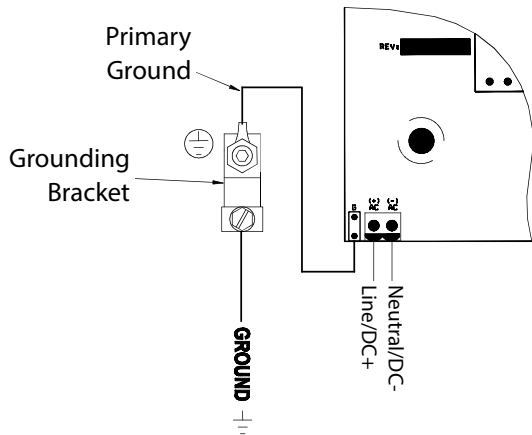

Figure 4. Main Relay Connections

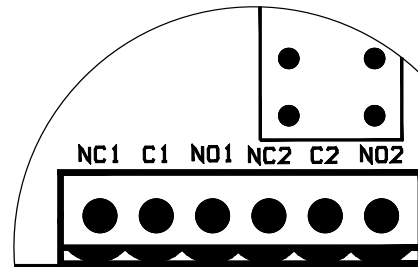
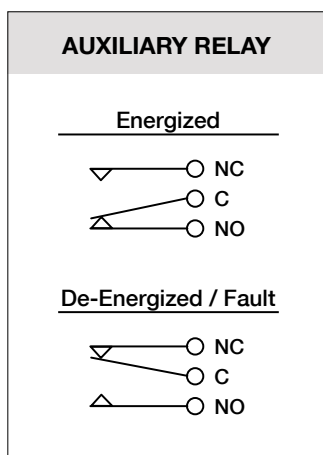
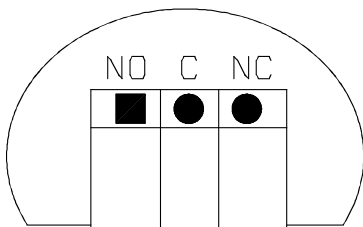

Figure 5. Auxiliary Relay Connections



WIRING & FAIL-SAFE SELECTION

The Roto-Bin-Dicator PRO is factory set for high level fail-safe operation. The Fail-Safe is controlled by SW3, position 1. Refer to Figure 6 to determine the Fail-Safe mode that suits your application.

Figure 6. Wiring & Fail-Safe Operation

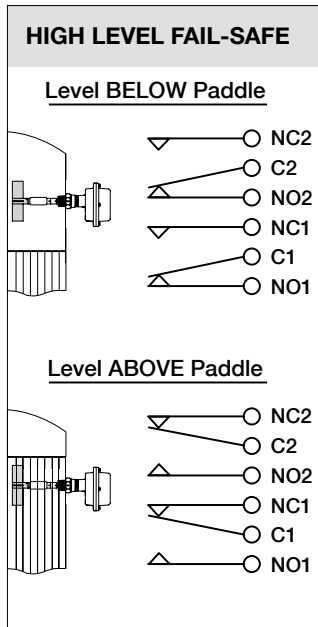

HIGH LEVEL FAIL-SAFE OPERATION (DEFAULT)

DIP Switch

- SW3-1 is OFF

Non-Alarm State (material below the paddle)

- Main Relay is energized
 - Relay NC contacts are open
 - Relay NO contacts are closed
- Alarm LED is OFF

Alarm State (material above the paddle)

- Main Relay is de-energized
 - Relay NC contacts are closed
 - Relay NO contacts are open
- Alarm LED is ON

Note: If the electrical power fails, the main relay turns OFF, giving the same indication as if material is above the paddle.

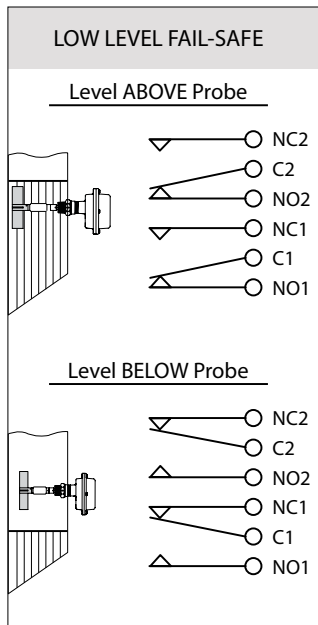

LOW LEVEL FAIL-SAFE OPERATION

DIP Switch

- SW3-1 is ON

Non-Alarm State (material above the paddle)

- Main Relay is energized
 - Relay NC contacts are open
 - Relay NO contacts are closed
- Alarm LED is OFF

Alarm State (material below the paddle)

- Main Relay is de-energized
 - Relay NC contacts are closed
 - Relay NO contacts are open
- Alarm LED is ON

Note: If the electrical power fails, the main relay turns OFF, giving the same indication as if material is below the paddle.

Figure 7. Enclosure with Cover Removed

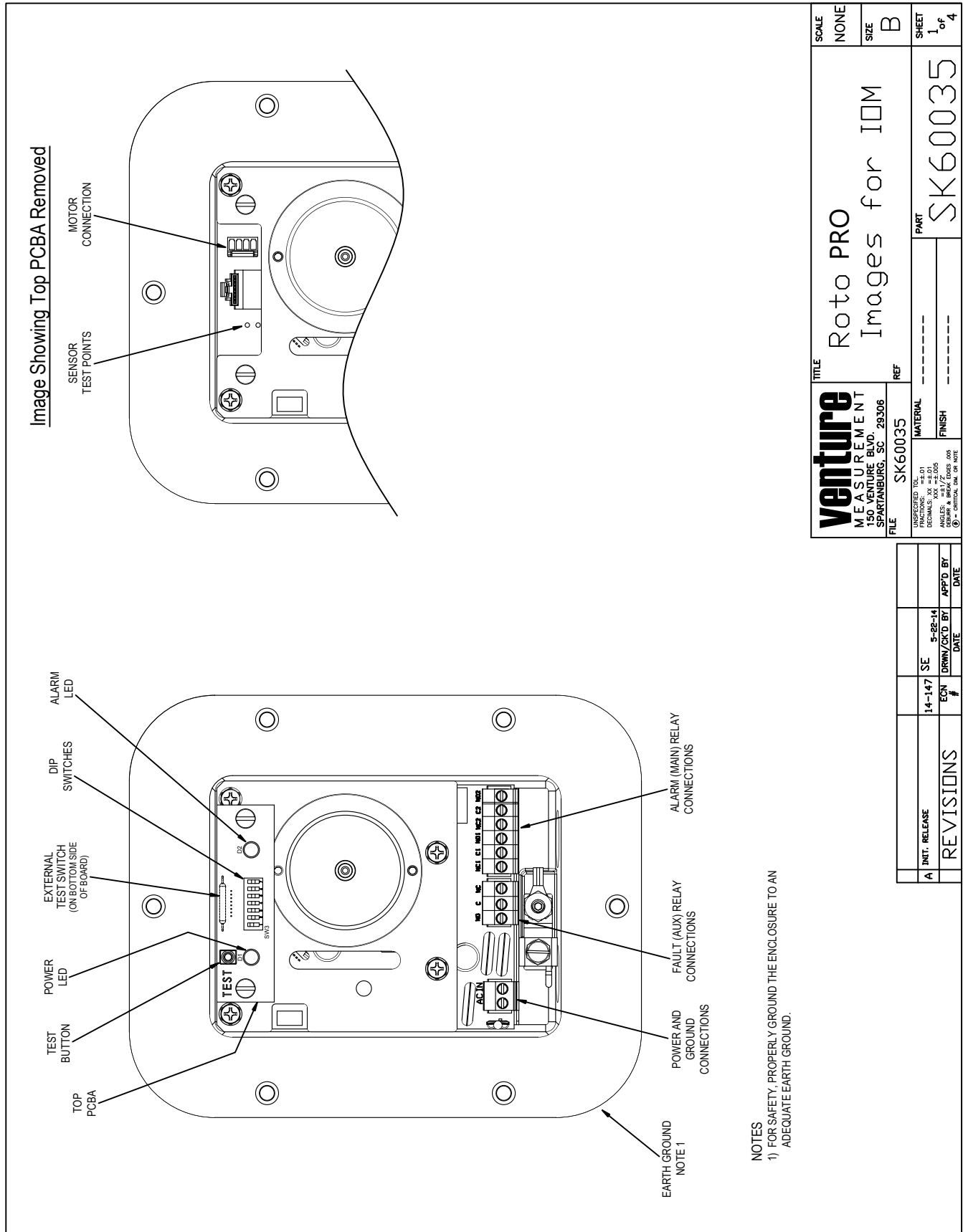

SCALE	NONE	SHEET	1 of 4
SIZE	B	PART	SK60035
TITLE	Roto PRO Images for IOM		
FILE	SK60035	REF	
UNSPECIFIED TOL.	0.01		
FRAC TOL.	0.01		
DECIMAL TOL.	0.01		
ANGLES	30° ± 0.05		
OPERATE & BREAK TOLER.	0.05		
②	CONTINUED ON NOTE		
MATERIAL	---		
FINISH	---		

REV	DATE	BY	DATE
A	14-147	SE	5-22-14
REVISIONS			
ECN #	DRN/CKD BY	APPD BY	DATE

VI. SET-UP



WARNING: VERY HIGH VOLTAGE IS PRESENT.

REMOVE POWER FROM THE UNIT BEFORE INSTALLING, REMOVING, OR MAKING ADJUSTMENTS

OPERATION

The Roto-Bin-Dicator PRO does not require calibration. When power is applied to the unit, the paddle will begin rotating, if it is not impeded by contact with material or some other object. The green Power LED will be illuminated whenever power is applied to the unit. The status of the red Alarm LED is determined by the selected fail-safe mode and whether or not the paddle is rotating. Refer to Fail-Safe Selection section.

For optimal performance, determine the following: (See Fault Option Dip Switch)

Fail-Safe Operation: Critical motor or gear train faults will de-energize BOTH the alarm relay and the fault relay OR

Independent Faults: The alarm and fault relays will remain completely independent from each other.

PRODUCT OVERVIEW

The Roto PRO is a rotary level control switch designed to detect the absence or presence of material and is used in powders and granular solids. A rotating paddle is used to sense the presence of material. The Roto Pro uses a stepper motor to precisely control the torque applied to the paddle and the speed of its rotation. The absence or presence of material is detected by monitoring the rotation of the paddle. The presence of material will cause the motor to stall and the electronics will detect this condition and initiate a change in state of the main relay. Similarly, the absence of material will allow the paddle to rotate freely. The Roto Pro incorporates redundant detection of paddle rotation which also affords the ability to detect motor and/or drive train failures and differentiate them from stall due to material. If a failure is detected a code will be flashed on the green Power LED. The Roto PRO comes with a full array of diagnostics to assist in pinpointing the cause of disruption to normal operation. Refer to the diagnostic section of the manual for full details.

When power is applied to the unit, the paddle will rotate (if not impeded by contact with material or some other object) and the green Power LED will be illuminated. The status of the red Alarm LED is determined by the selected fail-safe mode and whether or not the paddle is rotating. Refer to Fail-Safe Selection section.

Figure 8: Switch Functions, Standard

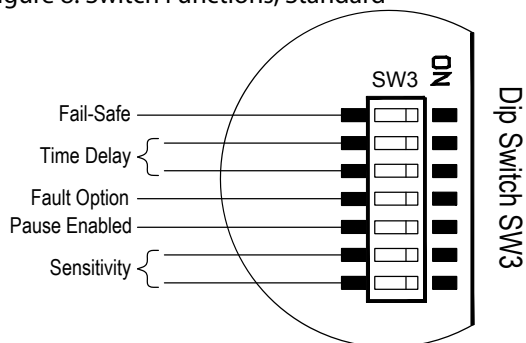

TIME DELAY SETTINGS

The Time Delay feature is used when the user wants to delay the activation or deactivation of the alarm relay for some predefined time after the absence or presence of material is detected. See Table.

To set the duration of the time delay, SW3, Positions 2 and 3 should be set using the table below. The time duration occurs in both directions, regardless of the fail-safe setting; so that the delay occurs between a detection and absence of material, and between an absence of material and detection.

SW3-2	SW3-3	Delay (sec.)
OFF	OFF	0
ON	OFF	7
OFF	ON	10
ON	ON	25

FAULT OPTION

This option should be activated in applications where a critical failure, such as motor or gear train failure (Fault 2, 4 or 5), warrants stopping the process to prevent material overfills or outages. This feature provides the user true fail-safe operation while maintaining the independence of the alarm and fault relays. To active the Fault Option, place SW3-4 to the ON position.

High-Level Operation:

With the Fault Option activated, a critical failure will cause the Roto-Bin-Dicator PRO to appear as if it is in material thereby preventing an overfill. For example, the Roto-Bin-Dicator PRO will move to the Alarm State (see page 9) and the fault relay will de-energize. The green LED will flash the fault code.

Low-Level Operation:

With the Fault Option activated, a critical failure will cause the Roto-Bin-Dicator PRO to appear as if it is not in material thereby preventing a material outage. For example, the Roto-Bin-Dicator PRO will move to the Alarm State (see page 9) and the fault relay will de-energize. The green LED will flash the fault code.

Activating the Fault Option provides benefit to users who control their process through the alarm relay only and prevents them from having to jumper the alarm and fault relays to obtain fail-safe operation. In cases where the user wants to separate the control of the process between the alarm and fault relays this option should be turned off (SW3-4 = OFF).

PAUSE MODE

The Pause function is used to extend the life of the Roto-Bin-Dicator PRO by reducing the wear on the motor bearings and geartrain. This function is particularly useful for vessels where the material level remains constant for extended periods (greater than 30 minutes). For example, storage silos where the material movement is limited. The pause function can be used for either low level or high level fail-safe operation and is enabled by SW3-5 being in the ON position. Please note that the operation of the alarm and fault relays are not affected by activating the Pause Mode and will continue to function as expected.

For the purpose of discussion, assume that a Roto-Bin-Dicator PRO is installed in a high level application and the Pause Mode is enabled. After 30 uninterrupted minutes of being in material, the Roto-Bin-Dicator PRO will enter the Pause Mode. While in this mode the Roto-Bin-Dicator PRO will check for the absence of material every 25 seconds. If during one of the checks the Roto-Bin-Dicator PRO detects the absence of material it will exit the Pause Mode and the paddle will rotate continuously. If the Roto-Bin-Dicator PRO now remains out of material for an extended period, it will re-enter the pause mode and paddle stops rotating continuously. As before, the Roto-Bin-Dicator PRO will now begin checking for material presence every 25 seconds to determine when to exit the Pause Mode.

SENSITIVITY SETTINGS

The Roto-Bin-Dicator PRO has four different sensitivity settings which can be selected by using SW3 positions 6 and 7; the unit ships from the factory set in the normal position. The user can increase or decrease the torque of the motor, therefore its sensitivity, by changing these switch settings as shown in the table below. Changing the sensitivity to the "High" position reduces the motor torque by 30% of "Normal" which increases the sensitivity of the Roto-Bin-Dicator PRO. Conversely, setting the unit to the "Low" position increases the motor's torque by 30% over "Normal" and thus decreases its sensitivity. The "Very Low" setting will increase the motor torque by 75% from normal.

SW3-6	SW3-7	Sensitivity
OFF	OFF	High
ON	OFF	Normal (Original Roto-Bin-Dicator)
OFF	ON	Low
ON	ON	Very Low

TEST

The Roto-Bin-Dicator PRO provides a means for self-test using the magnetic FOB provided with the unit or by pressing the TEST button. When the unit is not in material place and hold the FOB over the "TEST" label on the cover. If the unit is functioning properly, the alarm LED and main relay will change the state as shown below. When the test is completed and results verified, simply move the FOB away from the unit.

Pressing the test button will instantly change the state of the alarm LED and main relay.

A diagnostic test that validates the status of the motor and gear train will be initiated 15 seconds after the TEST button is pressed or the FOB is used.

HIGH FAIL-SAFE:

- Main relay de-energizes
- Red ALARM LED is on

LOW FAIL-SAFE

- Main relay energizes
- Red ALARM LED is off

Figure 11: Magnetic FOB

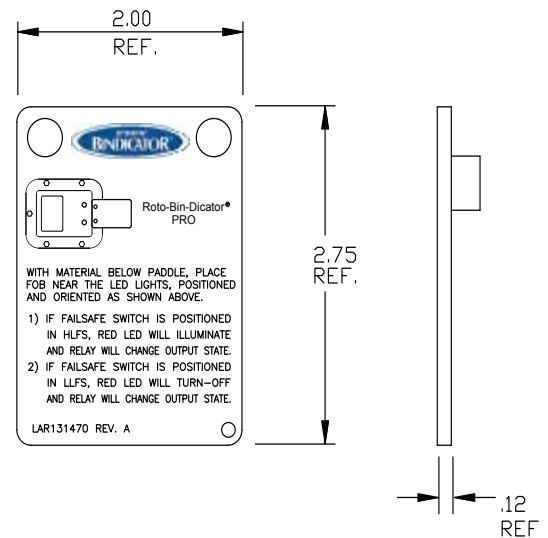

VII. MAINTENANCE



WARNING: IN ORDER TO MAINTAIN SAFE OPERATION IN HAZARDOUS LOCATIONS, THE INTEGRITY OF THE ALUMINUM CASTING AND THE EPDM SEALS MUST BE MAINTAINED. THE USER/INSTALLER MUST AVOID INSTALLATIONS WHERE AGGRESSIVE SUBSTANCES MAY BE PRESENT AND COULD AFFECT THE PERFORMANCE OF THESE MATERIALS. CARE MUST BE EXERCISED WHEN REMOVING AND REPLACING THE COVER, SO NO MARRING, SCRATCHING OR DAMAGE OCCURS TO THE FLANGES.



CAUTION: IF THE UNIT WAS SUPPLIED WITH A GASKET, AVOID FOLDING, CUTTING OR TEARING THE GASKET. DAMAGING THE GASKET CAN ALLOW MOISTURE TO ENTER THE ENCLOSURE AND DAMAGER THE UNIT

PREVENTATIVE MAINTENANCE

No scheduled preventative maintenance is required for the Roto-Bin-Dicator PRO units when properly applied and installed correctly. There is no cleaning required for the unit before or during installation.

If the cover is removed after the unit has been in service, it is recommended to replace the gasket to prevent the ingress of water or dust. At a minimum, the gasket should be inspected for folds, cracks and tears

RECOMMENDED SPARE PARTS

MOUNTING PLATES

Includes H-20 Mounting Gasket

PART NUMBER	MODEL	DESCRIPTION
LAR110130	H-19	Mild Steel (Side of Bin)
LAR110140	H-19SS	304 Stainless Steel (Side of Bin)
LAR110180	H-192	Mild Steel (Top of Bin)
LAR110190	H-192SS	304 Stainless Steel (Top of Bin)

COUPLINGS

PART NUMBER	MODEL	DESCRIPTION
LAR110270	H-36	Neoprene 3 in. Flexible Shaft; 170°F (77°C) Max Temp
LAR110275	H-36S	Molded Silicone 3 in. Flexible Shaft; 400°F (204°C) Max Temp
LAR120640	H-38	Stainless Steel (Used with extensions only)

PADDLES: All are stainless steel except model H-373.

PART NUMBER	MODEL	DESCRIPTION
LAR110310	H-370	4-Vane; 1 1/2" x 5" Diameter with Pins
LAR110360	H-371	4-Vane; 2" x 7" Diameter with Pins
LAR110430	H-373	Multiflex; Solid Neoprene 1 1/2" x 24" with Pins
LAR110450	H-374	Multiflex; Stainless Steel 1 1/2" x 17" with Pins
LAR111037	H-379	1-Vane; Insertable with Pins
LAR111040	H-372A	1-Vane; 1" x 2 7/8" with 45° Cut
LAR111200	H-380	2-Vane Collapsible, Stainless Steel

NOTE: Consult the manufacturing facility on applications where the housing ambient temperature is above 200°F (93°C).

SHAFT EXTENSIONS

PART NUMBER	DESCRIPTION
LUB040500	316 Stainless Steel, 1/8 in. pipe

SHAFT GUARDS

PART NUMBER	DESCRIPTION
LUB040510	316 Stainless Steel, 1-1/4" NPT

OTHER/MISCELLANEOUS

PART NUMBER	DESCRIPTION
FOB131470	Roto-Bin-Dicator PRO Test FOB
LUBK31891	External Ground Kit
LVPK38055	Internal Ground Kit
LUBK43300	Fiber Gaskets, Pack of 5
LUBK43304	Fiber Gasket, Metric, Pack of 5
LUBK43314	G-Thread Fitting Gasket, Pack of 5
LARK30380	H-20 Mounting Plate Gasket, Pack of 5
LUBK43003	Cover Hardware
LUBK43004	Cover Hardware, Metric
PROK04351	Roto-Bin-Dicator PRO Cover Kit
PROK04352	Roto-Bin-Dicator PRO Cover Kit, Metric
PROK11145	Roto-Bin-Dicator PRO Electronics Kit
PROK11146	Roto-Bin-Dicator PRO Light Board & Hardware Kit
PROK13088	Roto-Bin-Dicator PRO Motor & Plate Kit

VIII. TROUBLESHOOTING

LED BLINK CODE (Number of times)	FAULT
1	Low supply voltage or failing power supply
2	Motor disconnected
3	Temperature out of range
4	Bad motor
5	Bad gear train
6	I2C Bus error

	SYMPTOM	POSSIBLE CAUSE	SOLUTION
The unit is unresponsive	The auxiliary relay is de-energized and the power LED is off	There is no power at the unit	1) Verify adequate power is supplied to the unit at connector CN3 2) If the power supply is adequate, the unit is likely damaged, contact the manufacturer to order replacement parts
	The unit remains in alarm [LEDs and Alarm relay] even though the material level is below the paddle	Material has accumulated on the paddle	Remove debris from the paddle
	The unit remains in alarm [Alarm relay only] even though the material level is below the paddle	The alarm relay contacts are fused	Contact the manufacturer to order replacement parts

	SYMPTOM	POSSIBLE CAUSE	SOLUTION
The power LED is flashing	Green LED is flashing - 1 time	The output voltage of the power supply circuit board [bottom board] is too low	1) Using a multimeter, verify the supply voltage at connector CN3 is within the products operable range. 2) If the voltage is outside this range, check the wiring and the rating on the supply 3) Contact the manufacturer to order replacement parts.
	Green LED is flashing - 2 times	The motor is not connected to J2	Verify the connection between the power supply circuit board [bottom board] and the motor. The connection on the circuit board should be made at connector J2.
	Green LED is flashing - 3 times	The product has been installed outside its anticipated operating range	Move the unit to a lower temperature environment to prevent premature failure
	Green LED is flashing - 4 times	One of the windings of the motor has opened	1) Press the test switch to initiate a self-test and recheck the motor fault 2) If the fault persists, contact the factory for a motor/geartrain replacement

	SYMPTOM	POSSIBLE CAUSE	SOLUTION
The power LED is flashing	Green LED is flashing - 5 times	The geartrain is bound	1) Press the test switch to initiate a self-test and recheck the geartrain fault 2) Inspect the clutch mechanism for debris. If debris exists, remove it using a wire brush and lubricate the clutch bearing. 3) If the fault persists, contact the factory for a motor/geartrain replacement
	Green LED is flashing - 6 times	Communication has been lost between the power supply circuit board [bottom board] and the LED board [top board]	1) Cycle power and assess whether the fault goes away 2) Contact the manufacturer to order replacement parts



150 Venture Boulevard
Spartanburg, SC 29306
Tel: (800) 778-9242
Fax: (864) 574-8063
sales@bindicator.com
www.bindicator.com

venture
MEASUREMENT

2015 All rights reserved.
All data subject to change without notice.

LAR180414 Rev. B