



---

# InvisiLink™ Wireless Radio Installation & Operation Manual



# InvisiLink™ Wireless Radio Installation & Operation Manual

## CONTENTS

<b>I. HANDLING AND STORAGE.....</b>	<b>1</b>
INSPECTION AND HANDLING	
DISPOSAL AND RECYCLING	
STORAGE	
<b>II. GENERAL SAFETY.....</b>	<b>2</b>
AUTHORIZED PERSONNEL	
USE	
MISUSE	
<b>III. PRODUCT DESCRIPTION .....</b>	<b>3</b>
FUNCTION	
FEATURES	
TECHNICAL SPECIFICATIONS	
<b>IV. MECHANICAL INSTALLATION.....</b>	<b>4</b>
MOUNTING CONSIDERATIONS	
DRILLING HOLES IN THE ENCLOSURE	
PREPARE THE ENCLOSURE FOR CONDUIT	
Figure 1. Bottom View	
TO MOUNT THE INVISILINK ENCLOSURE	
TO MOUNT THE EXTENDED RANGE ANTENNA	
<b>V. ELECTRICAL INSTALLATION .....</b>	<b>6</b>
GENERAL SAFETY	
DISCONNECT REQUIREMENTS FOR PERMANENTLY INSTALLED EQUIPMENT	
RS-485/RS-422 EQUIPMENT MATRIX	
Figure 2: Wiring Diagram RS-422	
Figure 3: Wiring Diagram RS-485 (MODBUS)	
Figure 4: Wiring Diagram RS-422 with 4-20 mA Input Box	
<b>VI. SET-UP     9</b>	
Figure 5: LED Indicator Lights	
Figure 6. Point-to-Point	
Figure 7. Point-to-Point (Multi Device)	
Figure 8. Multi Point	
Figure 9. 4-20 mA Point-to-Point	
Figure 10: Dip Switches	

VII. MAINTENANCE ..... 12

VIII. TROUBLESHOOTING ..... 13

## SAFETY SYMBOLS



### **WARNING:**

IDENTIFIES CONDITIONS OR PROCEDURES, WHICH IF NOT FOLLOWED, COULD RESULT IN SERIOUS INJURY. RISK OF ELECTRICAL SHOCK.



### **CAUTION:**

IDENTIFIES CONDITIONS OR PROCEDURES, WHICH IF NOT FOLLOWED, COULD RESULT IN SERIOUS DAMAGE OR FAILURE OF THE EQUIPMENT.

# InvisiLink Wireless Radio

## I. HANDLING AND STORAGE

### **SAVE THESE INSTRUCTIONS**

#### **INSPECTION AND HANDLING**

Do not dispose of the carton or packing materials.

Each package should be inspected upon receipt for damage that may have occurred due to mishandling during shipping. If the unit is received damaged, notify the carrier or the factory for instructions. Failure to do so may void your warranty. If you have any problems or questions, consult Customer Support at 1-800-426-9010.

#### **DISPOSAL AND RECYCLING**

This product can be recycled by specialized companies and must not be disposed of in a municipal collection site. If you do not have the means to dispose of properly, please contact for return and disposal instructions or options.

#### **STORAGE**

If the device is not scheduled for immediate installation following delivery, the following steps should be observed:

1. Following inspection, repackage the unit into its original packaging.
2. Select a clean dry site, free of vibration, shock and impact hazards.
3. If storage will be extended longer than 30 days, the unit must be stored at temperatures between -40° and 158° F (-40° to 70° C) in non-condensing atmosphere with humidity less than 85%.



**CAUTION: DO NOT STORE A NON-POWERED UNIT OUTDOORS FOR A PROLONGED PERIOD.**

## II. GENERAL SAFETY

### **AUTHORIZED PERSONNEL**

All instructions described in the document must be performed by authorized and qualified service personnel only. Before installing the unit, please read these instructions and familiarize yourself with the requirements and functions of the device. The required personal protective equipment must always be worn when servicing this device.

### **USE**

The device is solely intended for use as described in this manual. Reliable operation is ensured only if the instrument is used according to the specifications described in this document. For safety and warranty reasons, use of accessory equipment not recommended by the manufacturer or modification of this device is explicitly forbidden. All servicing of this equipment must be performed by qualified service personnel only. This device should be mounted in locations where it will not be subject to tampering by unauthorized personnel.

### **MISUSE**

Improper use or installation of this device may cause the following:

- Personal injury or harm
- Application specific hazards such as vessel overflow
- Damage to the device or system

If any questions or problems arise during installation of this equipment, please contact Customer Support at 800-426-9010.

### III. PRODUCT DESCRIPTION

#### FUNCTION

InvisiLink is a wireless radio solution for devices that communicate via RS-485 or RS-422. A radio is connected to both the measuring device, like a Yo-Yo or controller, and the receiving device, like an ORB. Then the InvisiLink radio sends data back and forth between the devices. This system eliminates the need for cables and conduit connecting a measuring device to a device collecting data. It is also possible to have a single device receive multiple data streams from 'send' devices.

#### FEATURES

- Distances up to 3,000 ft (914 m)
- RS-485 or RS-422 Connection Capabilities
- NEMA 4X Enclosure
- Standard and Extended Range Antenna Options
- LED Indicator Lights

#### TECHNICAL SPECIFICATIONS

FUNCTION	
Input/Output	RS-485 or RS-422
Frequency	900 Mhz
Power Supply	120 VAC +/- 10%; 60Hz 30 watt
Ambient temperature	-40° to 185° F (-40° to +85° C)
PERFORMANCE	
Transmission Speed (Baud Rate)	RS-485: 115.2 RS-422: 9600
Transmit Power	1 mW to 1 W
Transmission Distance	3,000 ft (914 m)*
PHYSICAL	
Housing Material	NEMA 4X, Fiberglass
Extended Range Antenna	Up to 40 miles (64 km) NEMA 4X Outdoor includes lightning arrestor**, includes 2 ft (61 cm) connection cable
Visual Indicators	LED Lights (Power, Communication and Signal)

\*Distances may be reduced depending on environment. Maximum distance determined in indoor/urban environment with direct line of sight, no obstacles.

\*\* Consult Factory for extended range distances.

## IV. MECHANICAL INSTALLATION



**WARNING: REMOVE POWER FROM THE UNIT BEFORE INSTALLING REMOVING OR MAKING ADJUSTMENTS.**



**CAUTION: DO NOT ROUTE SERIAL CABLES IN THE SAME CONDUIT WITH AC POWER CABLES.**



**CAUTION: THIS DEVICE COMPLIES WITH PART 15 OF THE FCC RULES. OPERATION IS SUBJECT TO THE FOLLOWING TWO CONDITIONS: (I) THIS DEVICE MAY NOT CAUSE HARMFUL INTERFERENCE AND (II) THIS DEVICE MUST ACCEPT ANY INTERFERENCE RECEIVED, INCLUDING INTERFERENCE THAT MAY CAUSE UNDESIRE OPERATION.**

### MOUNTING CONSIDERATIONS

- Mounting hardware is not supplied by Kistler-Morse.
- When mounting the enclosure ensure there is enough clearance to open the front door completely. Removal, insertion, and wiring of the modular PCB is done through the front of the unit.
- Preferred direct line of sight between antennas (devices)
- Minimize metallic obstacles between devices
- Should not be close to high voltage sources



**WHEN SEALING CONDUIT CONNECTIONS, ONLY USE SIKAFLEX 1A POLYURETHANE SEALANT OR DOW CORNING RTV 738 OR 739. OTHER SEALANTS MAY CONTAIN ACETIC ACID WHICH IS HARMFUL TO SENSORS AND ELECTRONICS.**

### DRILLING HOLES IN THE ENCLOSURE

The standard fiberglass NEMA 4X rated enclosure has no openings through which to route cables or install the conduit. Hole location is critical for proper conduit installation. Check clearances to ensure that the fittings and wire routing will not interfere with the PCB or enclosure door.



**DO NOT DRILL HOLES THROUGH THE TOP OF ENCLOSURE AS THIS MAY ALLOW MOISTURE SEEPAGE, WHICH CAN DAMAGE THE ELECTRONICS AND VOID THE WARRANTY.**

### PREPARE THE ENCLOSURE FOR CONDUIT

1. Open door of the enclosure.
2. Remove all four (4) mounting screws that attach the board to the enclosure.
3. Remove entire board, and place in a safe location.
4. Make a separate hole for the AC cable, the serial and CAT 5 wiring. Holes should be made in the front 2 inches of the bottom of the enclosure (Figure 1); this allows for appropriate spacing for cables.

Figure 1. Bottom View

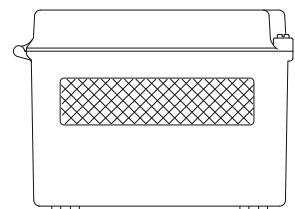



5. Clean enclosure of any debris, replace the board back into the enclosure, using all four (4) mounting screws.
6. Determine desired location for mounting the unit.

#### **TO MOUNT THE INVISILINK ENCLOSURE**

1. Hold the enclosure against the wall in the desired location and mark the positions of the mounting holes. Place the enclosure in a safe location.
2. Drill the mounting holes in the wall.
3. Attach the enclosure to the wall using hardware that will secure it firmly in place.

#### **TO MOUNT THE EXTENDED RANGE ANTENNA**

The extended range antenna can either be mounted with the attached plate or with U-bolts, both included as standard. The cable between the radio and the antenna is 2 ft (61 cm) in length; plan the location of the unit and antenna accordingly.

If using the plate, pre-drill holes in desired location and bolt to structure.

If using the U-bolts, determine location on pipe or pole to mount the antenna and attach with mounting hardware.

## V. ELECTRICAL INSTALLATION



**WARNING: REMOVE POWER FROM THE UNIT BEFORE INSTALLING, REMOVING OR MAKING ADJUSTMENTS**

### GENERAL SAFETY

When using electrical equipment, you should always follow basic safety precautions, including the following:

- The installation/wiring of this product must comply with all national, federal, state, municipal, and local codes that apply.
- Properly ground the enclosure to an adequate earth ground.
- Do not modify any factory wiring. Connections should only be made to the terminals described in this section.
- All connections to the unit must use conductors with an insulation rating of 300 V minimum, rated for 105 C, a minimum flammability rating of VW-1, and be of appropriate gauge for the voltage and current required (see specs).
- Do not allow moisture to enter the electronics enclosure. Conduit should slope downward from the housing. Install drip loops and seal conduit with silicone rubber product.

### DISCONNECT REQUIREMENTS FOR PERMANENTLY INSTALLED EQUIPMENT

A dedicated disconnecting device (circuit breaker) must be provided for the proper installation of the unit. If independent circuits are used for power input, individual disconnects are required. Disconnects must meet the following requirements:

- Located in close proximity to the device
- Easily accessible to the operator
- Appropriately marked as the disconnect for the device and associated circuit
- Sized appropriately to the requirements of the protected circuit (See Specifications)

### RS-485/RS-422 EQUIPMENT MATRIX

DEVICE	COMMUNICATION	
	RS-485	RS-422
Bindicator 3D Level Scanner	x	
Bindicator Mark-4/GP-4 Yo-Yo	x	
Bindicator/Kistler-Morse ORB	x	x
Bindicator/Kistler-Morse ORB 4-20mA Input Box		x
Bindicator SonoTracker		x
Kistler-Morse Ultrawave		x
Kistler-Morse MVS		x
Kistler-Morse STXplus		x
Kistler-Morse SVS2000		x
Kistler-Morse Weigh II		x
Niagara Meters 5600 Controller		x

Note: RS-485 Communication will be programmed at a baud rate of 115200;  
 RS-422 Communication will be programmed at a baud rate of 9600.

Figure 2: Wiring Diagram RS-422

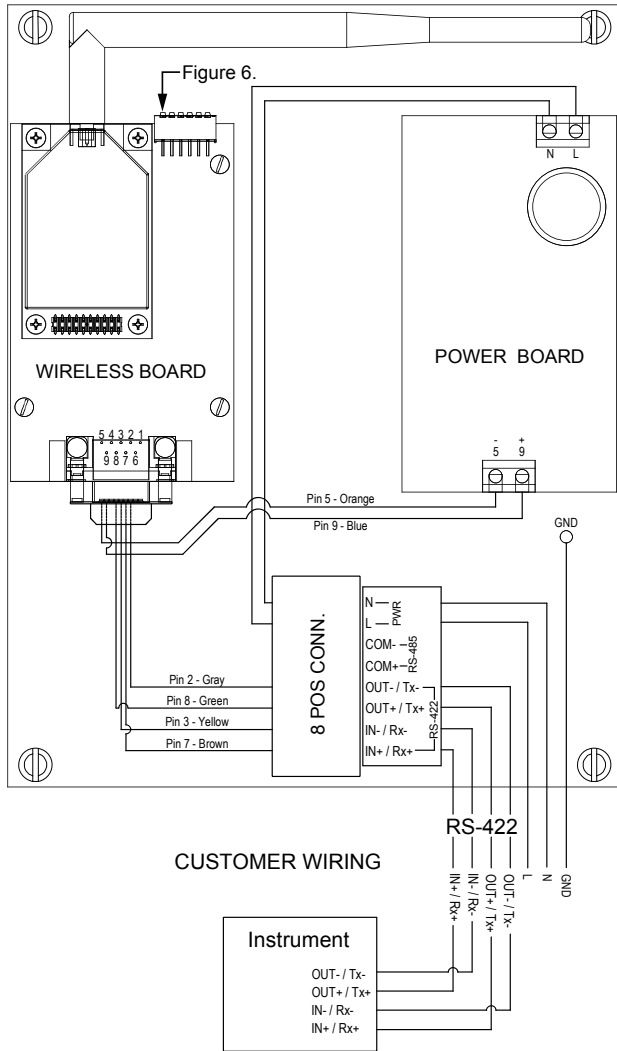

Figure 3: Wiring Diagram RS-485 (MODBUS)

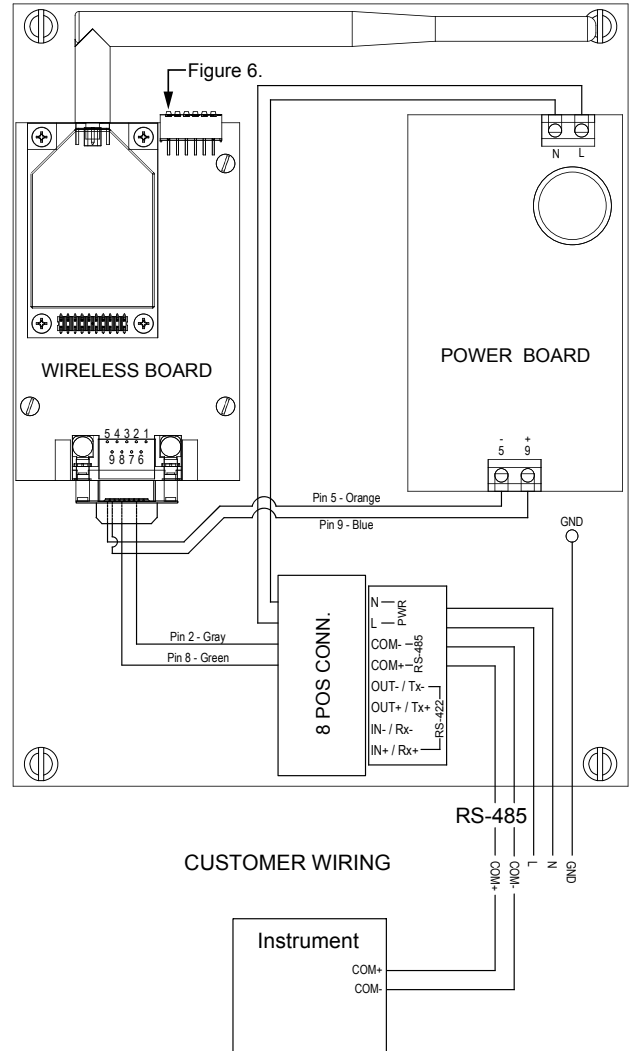
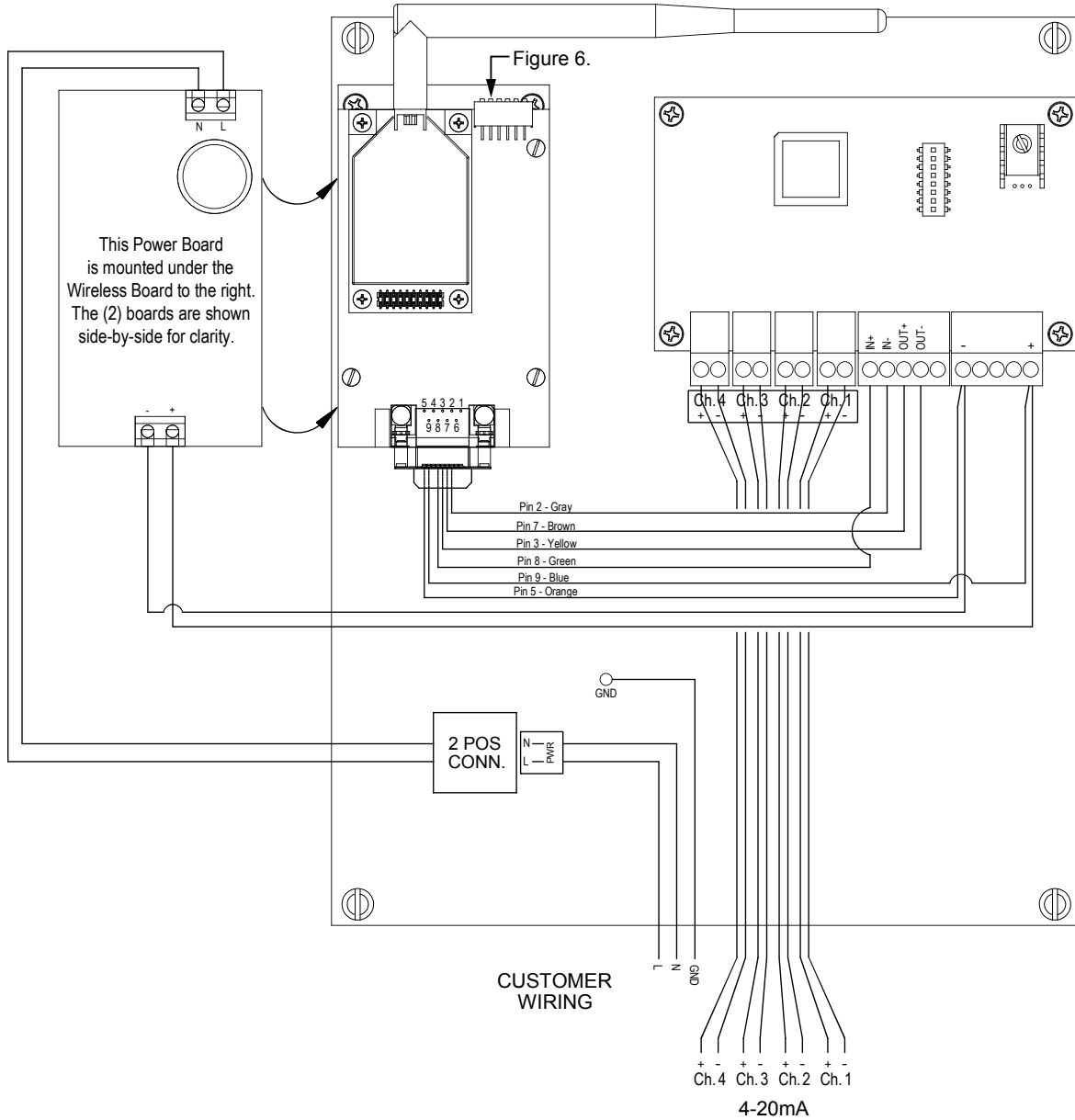

Figure 4: Wiring Diagram RS-422 with 4-20 mA Input Box



## VI. SET-UP

1. The enclosure has been mounted.
2. Determine Point to Point or Multi-Point configuration. See Figure 10 for Dip Switch settings.
3. Serial cable has been wired, and power has been wired and turned on.
4. Ensure the Power Indicator LED light is solid red and that Serial Data In/Out LEDs are flashing. See Figure 5.

No additional programming is required. All radio enclosures should automatically begin sending and receiving signals.

NOTE: Communication device types cannot be mixed. RS-485 devices must be connected to another RS-485 device; it will not receive signals to or from a RS-422 device.

To ensure unit is functioning properly, check the LED indicator lights.

**Figure 5: LED Indicator Lights**

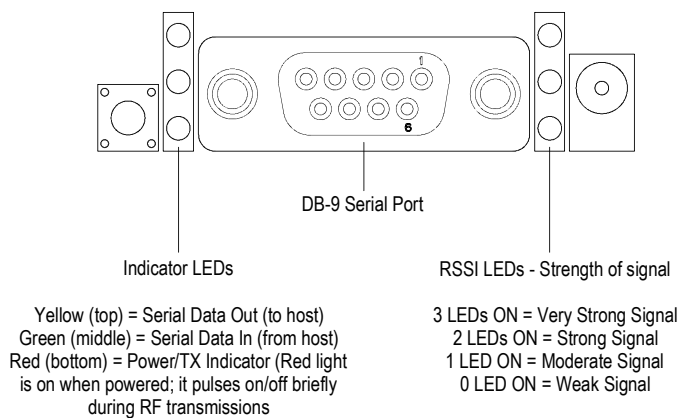

If indicator lights are not working, please proceed to the Troubleshooting section of this manual for assistance.

### Notes (Use for Figures 6-9):

1. All remote devices must use the same protocol.
2. If device protocol = RS485, then InvisiLink Base must be RS485.  
If Device Protocol = RS422 or 4-20 mA, then InvisiLink Base must be RS422.

**Figure 6. Point-to-Point**

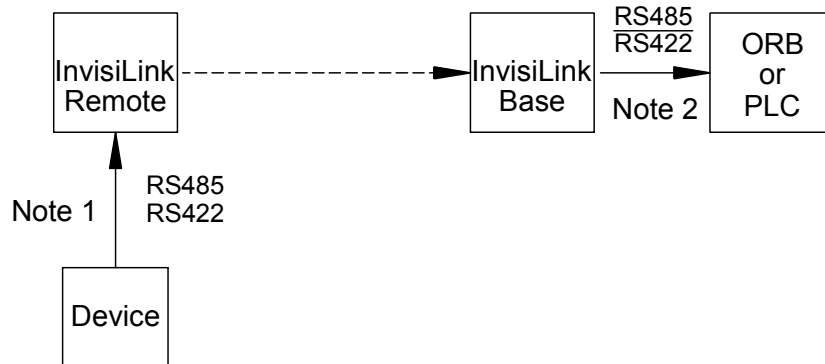

Figure 7. Point-to-Point (Multi Device)

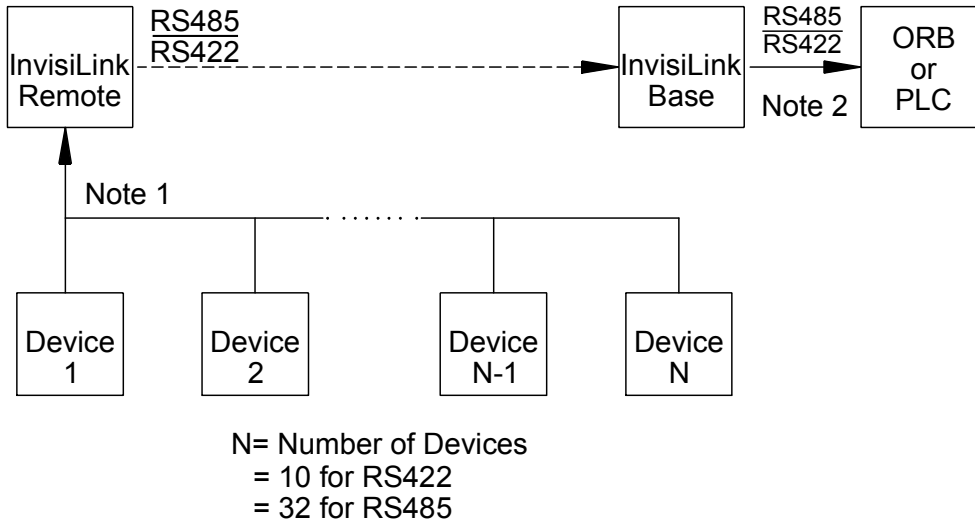
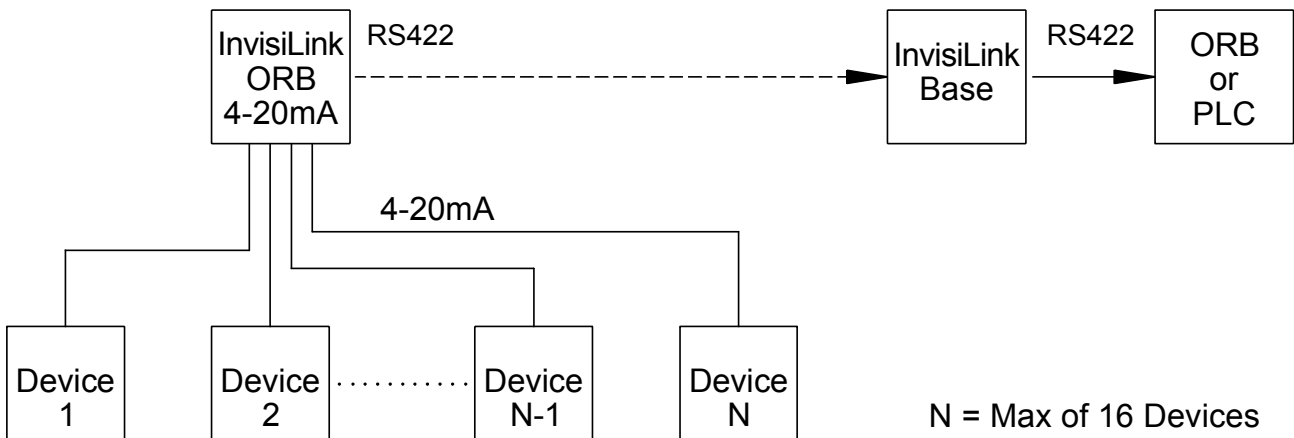

Figure 8. 4-20 mA Point-to-Point



### CHANGING POINT-TO-POINT TO MULTI-POINT

1. Determine the multipoint base, should be the device connected to the PCL or ORB, change Dip Switches 5 and 6 to the OFF position.
2. All other units will be considered multipoint remote units; change Dip Switch 5 to OFF and Dip Switch 6 to ON.
3. Serial cable should be wired, and power has also been wired and turned on.
4. Ensure the Power Indicator LED light is solid red and that Serial Data In/Out LEDs are flashing. See Figure 5.

Figure 9. Multi Point

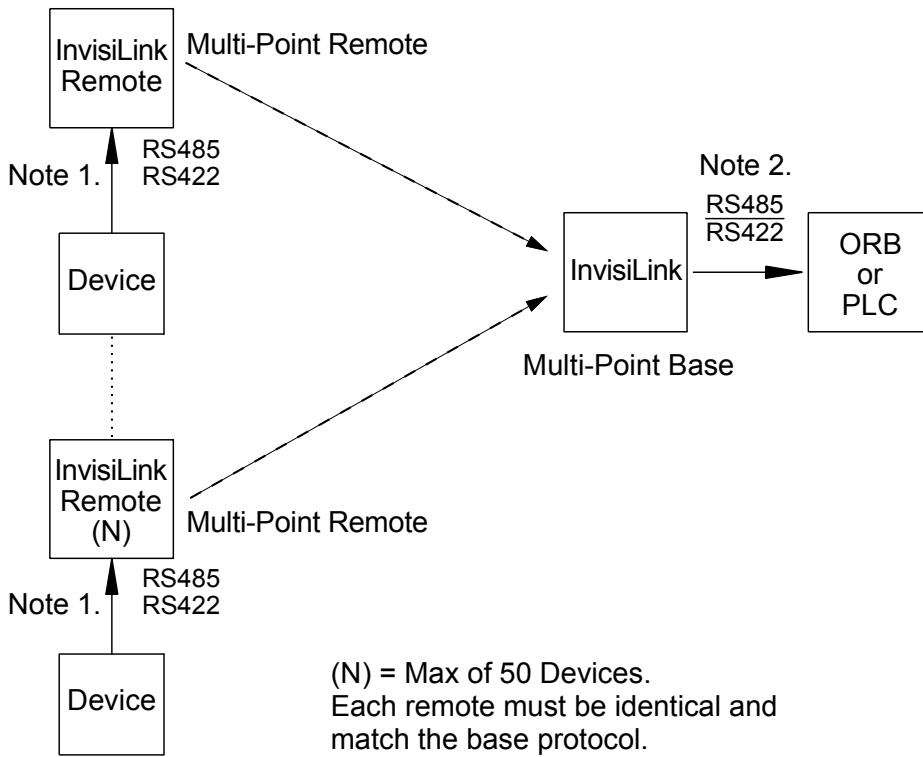

To set multi-point units, see figure 10 for dip switch settings.

Figure 10: Dip Switches

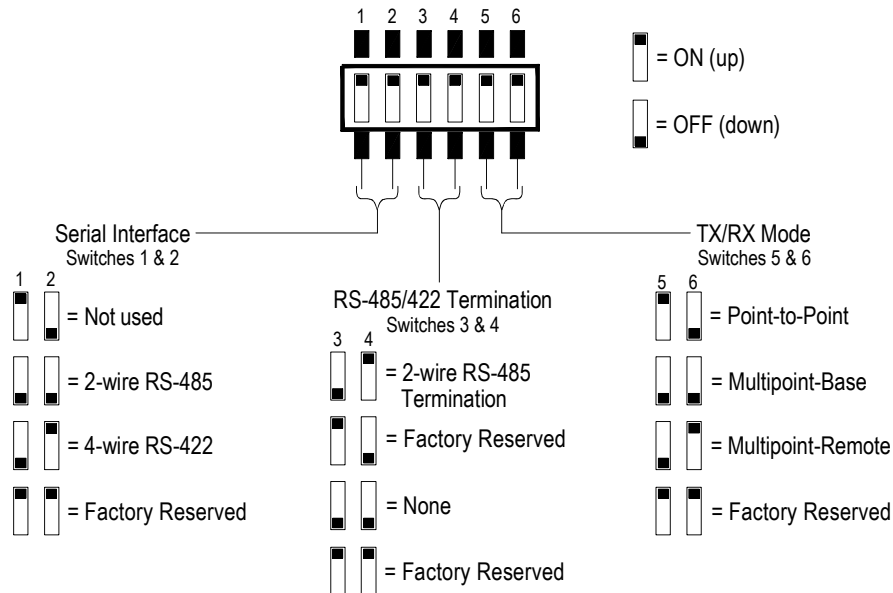

NOTE: Point to point is used when one radio is talking to one radio only; multi-point is used when there are multiple remotes and/or bases.

## VII. MAINTENANCE

### PREVENTATIVE MAINTENANCE

See ORB 4-20mA Input Box IOM for specific maintenance and possible replacement parts for the ORB 4-20mA Input Box unit. There is no preventative maintenance for a single unit radio.

### REPLACEMENT PARTS

- LUC044016 Extended Range Antenna, 2 ft (61 cm) Connection Cable
- LUC044023 Extended Range Antenna, 10 ft (3 m) Connection Cable
- LUC044005 Extended Range Antenna Lightning Arrestor



## VIII. TROUBLESHOOTING

For technical or service questions, please call the manufacturer Customer Support at 1-800-426-9010.

For detailed dimensional drawings, go to [www.kistlermorse.com](http://www.kistlermorse.com)

SYMPTOM	POSSIBLE CAUSE	CORRECTIVE ACTION
RSSI LEDs not on	Radio(s) are not powered on	Make sure the Indicator LED is red; if not check wiring
	Protocol switches do not match	Check dip switches and change if needed
	Antenna not connected	Tighten antenna and put in most direct line of sight to other radio
Red Indicator LED is not on	Not wired correctly	Reference wiring diagrams and check wiring
Top and or middle Indicator LEDs is not flashing	Both (all) radios may not be powered on	Make sure the Indicator LED is red; if not check wiring on both (all) units.
	Units are not communicating	Check all wiring

**NOTES**

---

---

---

---

---

---

---

---

---

---

---

---

---

---

---

---

---

---

---

---

---

---

---

---

---

---





150 Venture Boulevard  
Spartanburg, SC 29306  
Tel: (800) 426-9010  
Tel: (864) 574-2763 [Local]  
Fax: (864) 574-8063  
sales@kistlermorse.com  
www.kistlermorse.com

**venture**  
MEASUREMENT

2014 All rights reserved.  
All data subject to change without notice.

97-1502-13 Rev. B