



ORB™ Inventory Management System Installation & Operation Manual

ORB™ Inventory Management System Installation & Operation Manual

CONTENTS

I.	HANDLING AND STORAGE.....	1
	Inspection and Handling	
	Disposal and Recycling	
	Storage	
II.	GENERAL SAFETY	2
	Authorized Personnel	
	Use	
	Misuse	
III.	PRODUCT DESCRIPTION	2
	Function	
	Applications	
	Technical Specifications and Approvals	
IV.	MECHANICAL INSTALLATION	5
	To Mount the ORB™	
	Drilling Holes in the Enclosure	
	Figure 1: Bottom View	
V.	ELECTRICAL INSTALLATION	6
	General Safety	
	Disconnect Requirements for Permanently Installed Equipment	
	Protective Earth Ground	
	Wiring Diagrams	
	Figure 2: Wiring for RS-422 Serial Connections	
	Figure 3: Wiring for RS-485 Connections (Modbus)	
VI.	SET-UP	10
	For Ethernet Connection	
	For Serial Connection	
VII.	USING THE ORB.....	13
VIII.	TROUBLESHOOTING	16
IX.	DIMENSIONAL DRAWINGS.....	17

SAFETY SYMBOLS



WARNING:

IDENTIFIES CONDITIONS OR PROCEDURES, WHICH IF NOT FOLLOWED, COULD RESULT IN SERIOUS INJURY. RISK OF ELECTRICAL SHOCK.



CAUTION:

IDENTIFIES CONDITIONS OR PROCEDURES, WHICH IF NOT FOLLOWED, COULD RESULT IN SERIOUS DAMAGE OR FAILURE OF THE EQUIPMENT.

ORB™ Inventory Management System

I. HANDLING AND STORAGE

SAVE THESE INSTRUCTIONS

INSPECTION AND HANDLING

Do not dispose of the carton or packing materials.

Each package should be inspected upon receipt for damage that may have occurred due to mishandling during shipping. If the unit is received damaged, notify the carrier or the factory for instructions. Failure to do so may void your warranty. If you have any problems or questions, consult Customer Support at 1-800-778-9242.

DISPOSAL AND RECYCLING

This product can be recycled by specialized companies and must not be disposed of in a municipal collection site. If you do not have the means to dispose of properly, please contact Bindicator for return and disposal instructions or options.

STORAGE

If the device is not scheduled for immediate installation following delivery, the following steps should be observed:

1. Following inspection, repackage the unit into its original packaging.
2. Select a clean dry site, free of vibration, shock and impact hazards.
3. If storage will be extended longer than 30 days, the unit must be stored at temperatures between -40 and 158° F (-40 to 70° C) in non-condensing atmosphere with humidity less than 85%.



CAUTION: DO NOT STORE A NON-POWERED UNIT OUTDOORS FOR A PROLONGED PERIOD.

II. GENERAL SAFETY

AUTHORIZED PERSONNEL

All instructions described in the document must be performed by authorized and qualified service personnel only. Before installing the unit, please read these instructions and familiarize yourself with the requirements and functions of the device. The required personal protective equipment must always be worn when servicing this device.

USE

The device is solely intended for use as described in this manual. Reliable operation is ensured only if the instrument is used according to the specifications described in this document. For safety and warranty reasons, use of accessory equipment not recommended by the manufacturer or modification of this device is explicitly forbidden. All servicing of this equipment must be performed by qualified service personnel only. This device should be mounted in locations where it will not be subject to tampering by unauthorized personnel.

MISUSE

Improper use or installation of this device may cause the following:

- Personal injury or harm
- Application specific hazards such as vessel overflow
- Damage to the device or system

If any questions or problems arise during installation of this equipment, please contact Customer Support at 800-778-9242.

III. PRODUCT DESCRIPTION

FUNCTION

The ORB™ Inventory Management System is an information integration system that interfaces with various instruments and internet/intranet networks. The ORB transforms data from field instruments into useful information that enables plant and administrative personnel to more efficiently manage inventory and materials. The heart of the system is the ORB which acts as a hub for information from various systems, or future products.

The ORB diagram illustrates the various modes of input, output, and communication that can be established with the ORB. The ORB may be connected digitally with Bindicator® SonoTracker™ and Yo-Yo™ continuous level systems, as well as with Kistler-Morse® single-vessel and multi-vessel weighing systems. Additionally, any 4-20 mA device may be connected to the ORB Inventory Management System using the ORB 4-20 mA Input Box (sold separately).

APPLICATIONS

The ORB communicates serially simplifying wiring and interconnection to various current and future inventory systems. To communicate the information to users, it includes an RJ45 network port. Data is displayed in a graphical format using its built-in web server to provide current inventory information in both a tabular and graphical format, historical trending, raw data access and access to the actual inventory measurement systems connected to the ORB.

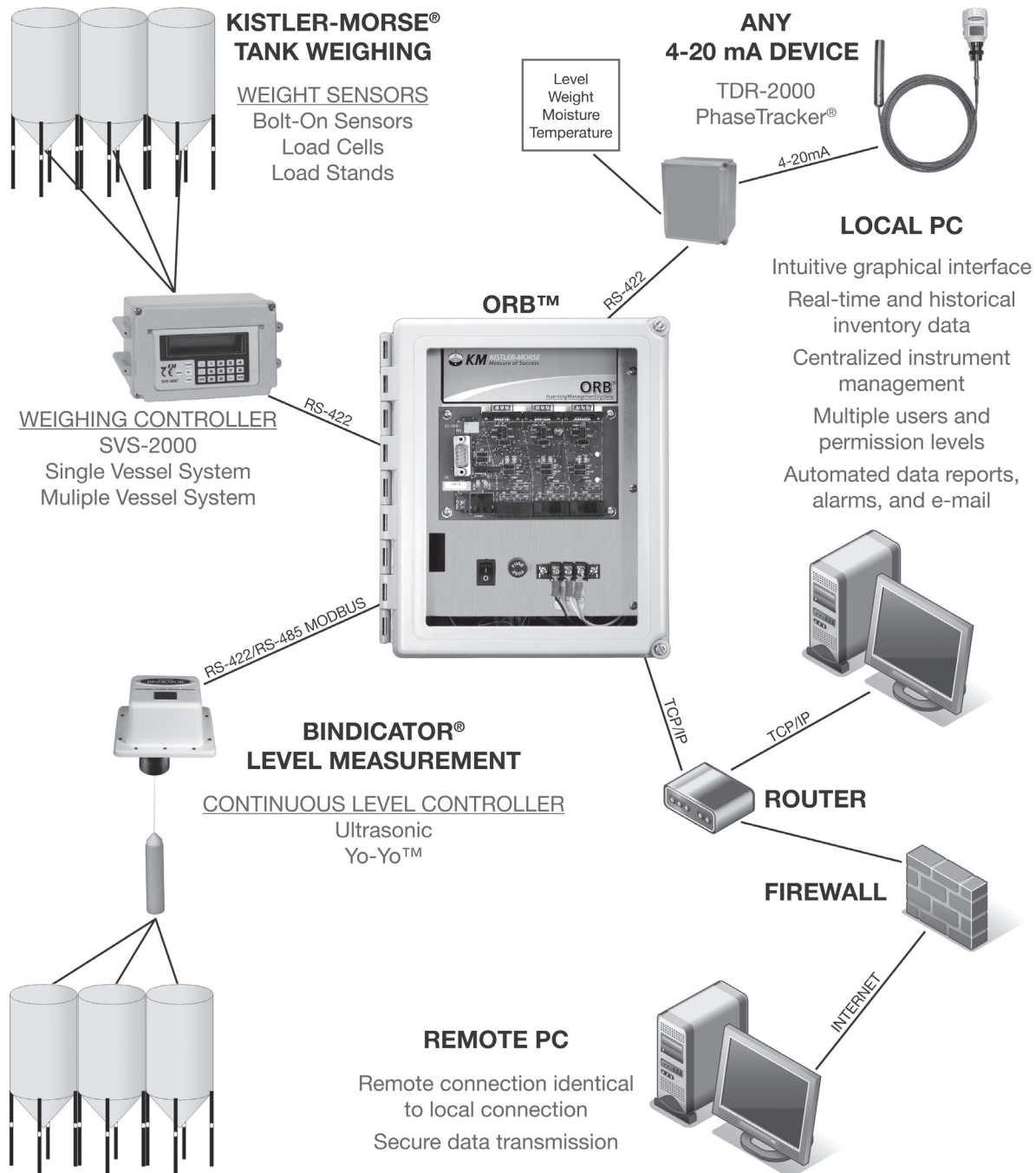

SPECIFICATIONS

Types of Data Available	Material level and weight; any process variable available from a 4-20 mA signal *
	Historical data
	Alarm conditions
	Logs of user access and configuration changes
Data Access Methods	Over intranet or internet via web browser
	Data download to spreadsheet or delimited file
	Automatic transmission to client database in XML format
Alarm Alerts	Any user-specified condition for level, weight, or other process variables
	Malfunction status of connected devices
	Alarm conditions viewable via web
	Alerts transmitted electronically to e-mail, handheld devices
System Setup	Plug-and-play configuration with most Bindicator and Kistler-Morse® systems
	Customized units of measure
	Frequency of data collection
	User configuration and access permissions
Device Compatibility	Bindicator Level Devices: GP-4 and Mark-4 Yo-Yo™ (Version 1.05 or higher), Sonotracker™ Ultrasonics, TDR-2000 Guided Wave Radar (via 4-20 mA input), 4-20mA Input Box
	Kistler-Morse Weighing Systems: SVS 2000, Weigh II (Rev B firmware or higher), STX ⁺ , MVS (Rev G firmware or higher), Sono II (Rev L firmware or higher); Ultra-wave™ , 4-20 mA Input Box
Communication Ports	1 Ethernet TCP/IP (RJ45)
	3 RS-422/485/232C
Power Supply Requirements	90 VAC to 254 VAC; 40 watts
Operating Temperature	-22° to 125° F (-30° to 52° C) Humidity: 0 - 100% non-condensing
Enclosure	NEMA-4X, Fiberglass Reinforced Plastic
Physical Dimensions	10.5" H x 8.5" W x 6.5" D (130.2 mm x 215.9 mm x 165.1 mm) 6.5 lbs (2.95 kg)
Mounting hole pattern	10.94" x 6" (278.87 mm x 152.40 mm)
Approvals	CE

* A separate ORB 4-20 mA input box is required.

IV. MECHANICAL INSTALLATION



WARNING: TO PREVENT PERSONAL INJURY OR EQUIPMENT DAMAGE ONCE THE ORB HAS BEEN CONNECTED TO POWER, DISCONNECT POWER BEFORE ADDING OR REMOVING PCBS OR MOUNTING THE STAND-ALONE ORB AND DEACTIVATE POWER TO THE CONTROLLER.



CAUTION: DO NOT ROUTE SERIAL CABLES IN THE SAME CONDUIT WITH AC POWER CABLES. ONLY USE SIKAFLEX 1A POLYURETHANE SEALANT OR DOW CORNING RTV 738 OR 739. OTHER SEALANTS MAY CONTAIN ACETIC ACID WHICH IS HARMFUL TO SENSORS AND ELECTRONICS. DO NOT DRILL HOLES THROUGH THE TOP AS THIS MAY ALLOW MOISTURE SEEPAGE, WHICH CAN DAMAGE THE ELECTRONICS AND VOID THE WARRANTY.

Notes:

1. Mounting hardware is not supplied by Bindicator.
2. When mounting the ORB be sure there is enough clearance to open the front door completely. Removal, insertion, and wiring of the modular PCB is done through the front of the unit.

DRILLING HOLES IN THE ENCLOSURE

The standard fiberglass ORB NEMA 4X rated enclosure has no openings through which to route cables or install the conduit. Hole location is critical for proper conduit installation. Check clearances to ensure that the fittings and wire routing will not interfere with the PCB or enclosure door.

PREPARE THE ENCLOSURE FOR CONDUIT

1. Open door of the ORB.
2. Remove all four (4) mounting screws that attach the ORB to the enclosure.
3. Remove entire ORB frame, and place in a safe location.
4. Make a hole for the AC cable and the serial and CAT 5 wiring. Holes should be made in the front 2 inches of the the bottom of the enclosure (see Figure 1); this allows for appropriate spacing for the ORB and cables.
5. Clean enclosure of any debris, replace the ORB back into the enclosure, using all four (4) mounting screws.
6. Determine desired location for mounting the ORB.

Figure 1.

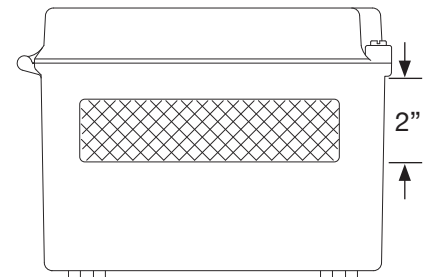

Bottom View

TO MOUNT THE ORB

1. Install feet to the ORB enclosure, tightening at the desired angles for mounting location.
2. Hold the enclosure against the wall in the desired location and mark the positions of the mounting holes. Place the enclosure in a safe location.
3. Drill the mounting holes in the wall.
4. Attach the enclosure to the wall using hardware that will secure it firmly in place.

V. ELECTRICAL INSTALLATION



WARNING: REMOVE POWER FROM THE UNIT BEFORE INSTALLING, REMOVING, OR MAKING ADJUSTMENTS

GENERAL SAFETY

When using electrical equipment, you should always follow basic safety precautions, including the following:



- The installation/wiring of this product must comply with all national, federal, state, municipal, and local codes that apply.
- Properly ground the enclosure to an adequate earth ground.
- Do not modify any factory wiring. Connections should only be made to the terminals described in this section.
- All connections to the unit must use conductors with an insulation rating of 300 V minimum, rated for 105 C, a minimum flammability rating of VW-1, and be of appropriate gauge for the voltage and current required (see specs).
- Do not allow moisture to enter the electronics enclosure. Conduit should slope downward from the housing. Install drip loops and seal conduit with silicone rubber product.

DISCONNECT REQUIREMENTS FOR PERMANENTLY INSTALLED EQUIPMENT

A dedicated disconnecting device (circuit breaker) must be provided for the proper installation of the unit. If independent circuits are used for power input and main relay outputs, individual disconnects are required. Disconnects must meet the following requirements:

- Located in close proximity to the device
- Easily accessible to the operator
- Appropriately marked as the disconnect for the device and associated circuit
- Sized appropriately to the requirements of the protected circuit (See Specifications)

PROTECTIVE EARTH GROUND

To eliminate shock hazards in the unlikely event of an internal insulation breakdown, the unit is provided with a “protective earth” () lead which must be connected to earth ground (). In addition, the input power ground lead must be connected to the “protective earth” () terminal provided. Wire sizes must be selected such that it can safely carry the sum total of all circuits’ maximum amperage.

WIRING POWER DIAGRAMS

- All wiring shown is customer installed.
- Route all AC wiring separate from all other wiring.
- To prevent ground loops, connect signal wire shields at one end only.
- Each of the three (3) COM ports can be configured individually for the RS-422 or RS-485 to satisfy the COM requirements of the equipment that the ORB is being connected to. Up to 100 pieces of RS-422 or RS-485 based equipment can be connected to a single COM port provided that each piece of equipment is given a unique address.
- For Ethernet applications, maximum cable length is 300 ft (90 m).
- For RS-232 applications, maximum cable length is 50 ft (15 m).
- For RS-422 applications, maximum cable length is 4000 ft (1200 m). Recommend using Belden® 8723 or equivalent.
- For RS-485 applications, maximum cable length is 4000 ft (1200 m). Recommend using 22 AWG 2 pair twisted shield Belden 8723 or equivalent.

FIGURE 2: Wiring For RS-422 Serial Connections

KM/RS-422 Jumper Configuration

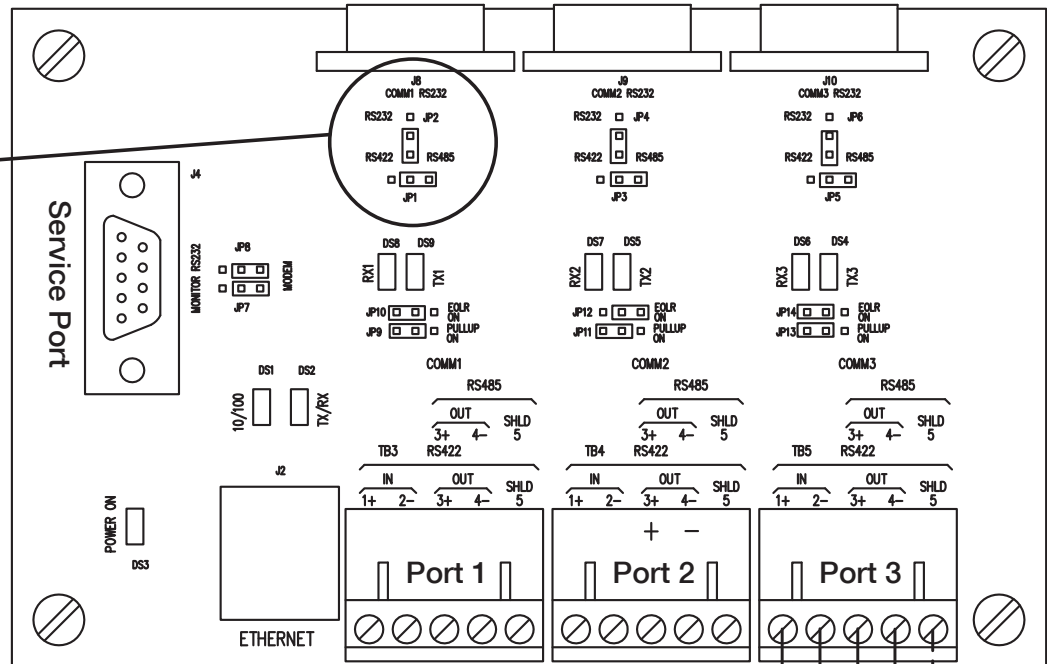
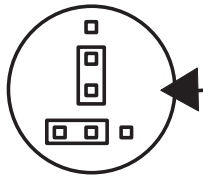

RS-422 Serial Connections

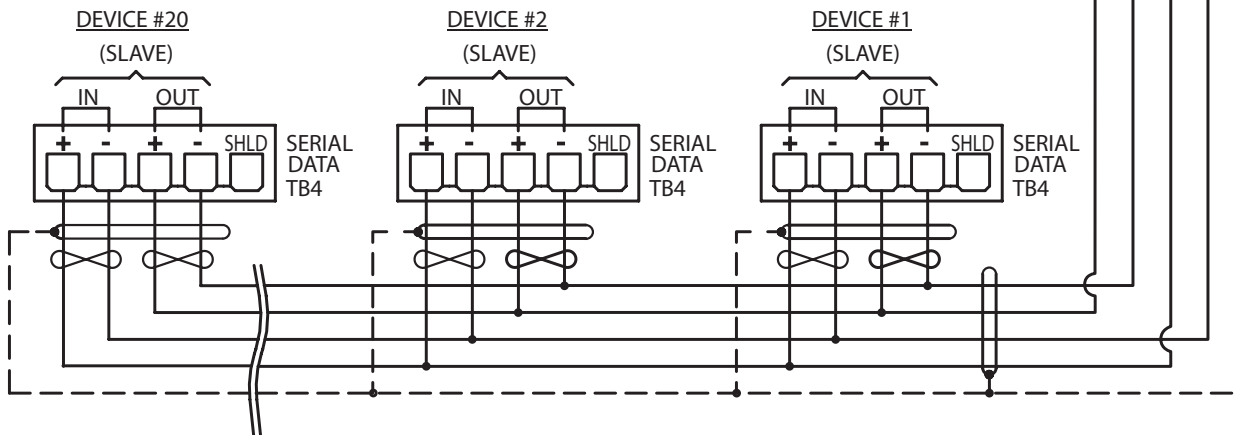
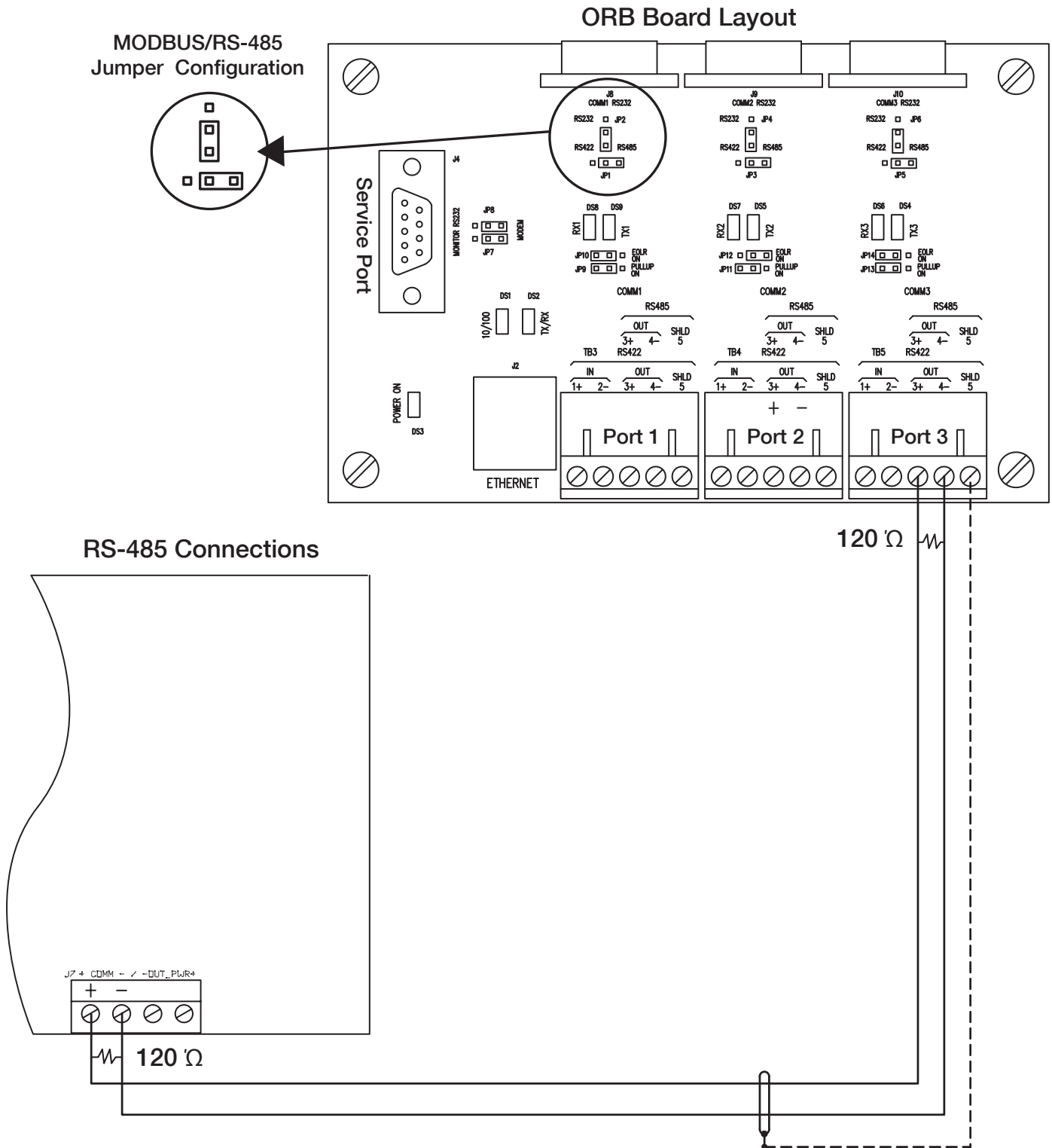

FIGURE 3: Wiring For RS-485 Connections (Modbus)



VI. SET-UP

To set up the ORB, first determine if an Ethernet or Serial Connection is being used.

FOR ETHERNET CONNECTION

Requires cross-over cable.

1. Go to Control Panel, choose Network Connections.
2. Identify the correct Network Connection, not a wireless connection.
3. Choose Properties of chosen Network Connection.
4. Choose Properties of the TCP/IP Protocol.
5. Write down the current computer IP address.
6. Change the computer IP address to 192.168.1.171 with a sub-address of 255.255.255.0; gateway is left blank
7. Apply changes. Rebooting the computer may be necessary.
8. Connect the cross-over cable from the Ethernet port on the ORB to the Ethernet port in the computer; watch Network icon for connectivity.
9. Launch a web browser.
10. Type 192.168.1.170 into the address window.
11. Log into the ORB using a web browser.
User Login = Admin
Password = Admin

NOTE: If using Internet Explorer, the time must be changed to the local time.

12. Choose Set Up EtherNet on the main screen

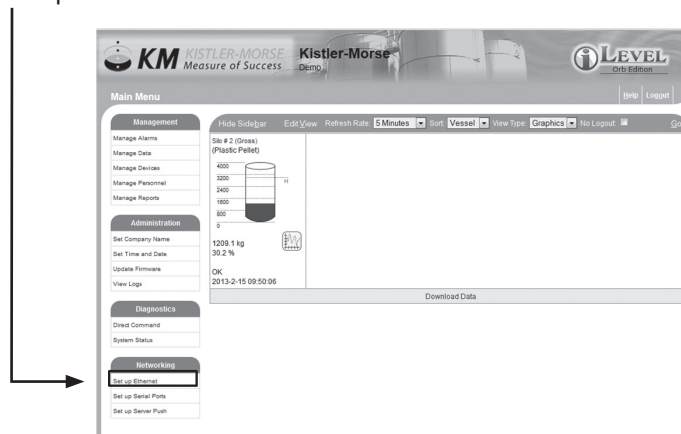

13. Match the ORB IP address to the assigned IP address, assigned by your IT group.
14. Choose Update ORB
15. Confirmation screen will appear, review and click OK
16. Disconnect the cross over cable and plug the ORB into your network.
17. Open new Internet browser and type in new IP address.

18. Now the ORB is ready to work on your network.
19. Close the browser to log out of the ORB.
20. Change the computer IP address back to the original - this is the IP address written down in Step 5 (See Steps 1-5 to access the address location again)

CREATE A RECORD TABLE

NOTE: Each device on a serial network must have a unique serial address. Each product can be set differently, refer to the Installation & Operation manual for individual products. The table below can be used to capture the required data for each device, add rows as needed.

SILO DESCRIPTION	PRODUCT NAME (MODEL)	SERIAL ADDRESS (DECIMAL)
Sample: North silo	Yo-Yo	000

TO SET UP THE VESSELS IN THE ORB

1. Log in to the ORB normally using a web browser.
 - User Login = Admin
 - Password = Admin
2. Scan for devices
 - a. Go to the NETWORKING tab
 - b. Click Set Up Serial Ports
 - c. Choose the Port that corresponds with the wiring of the ORB, click Configure
 - d. Choose the setting that matches the jumper setting (RS-485/MODBUS or KM/RS-422), click Update
 - e. Choose Manually Add Devices
 - f. Locate each serial address block (reference record table if required), click SCAN
 - g. Click continue, repeat until all devices have been successfully added. The ORB is now ready to begin taking readings.
3. A company administrator should be set up, as well as, any additional user profiles. See Using the ORB, Section VII for detailed instructions.

FOR SERIAL CONNECTION

Requires a DB9 cable (Null modem only – female both ends) and PuTTY.exe for the connection. PuTTY.exe can be download from the Bindicator website (www.bindicator.com).

1. Plug DB9 cable into ORB service port and your computer COM port.
2. Open Putty Configuration
3. Type COM1 into Serial Line field.
4. Select the Serial button for Connection Type

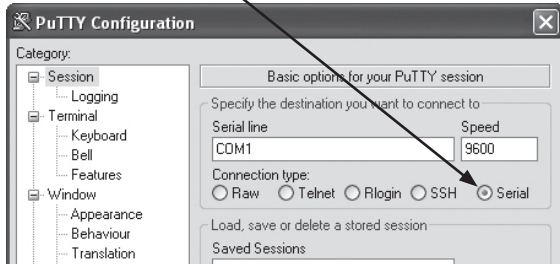

5. Click open
6. A blank screen may appear, until ENTER is pressed.
7. Enter USER NAME = kmc, press ENTER
8. Enter PASSWORD = kmc, press ENTER
9. Press 1 and ENTER to configure the network
10. Press 1 to change the IP address, press ENTER
11. Enter new IP address - provided by your IT group, press ENTER
12. Press 2 to change the Subnet/Netmask, press ENTER
13. Enter new Subnet/Netmask - provided by your IT group, press ENTER
14. Press 3 to change the Gateway, press ENTER
15. Enter new Gateway - provided by your IT group, press ENTER
16. Press 'S' to save the settings, press ENTER.
17. Close Putty program.
18. Connect to the ORB to your network.
19. Log in to the ORB using a web browser.

CREATE A RECORD TABLE

NOTE: Each device on a serial network must have a unique serial address. Each product can be set differently, refer to the Installation & Operation manual for individual products). The table below can be used to capture the required data for each device, add rows as needed.

SILO DESCRIPTION	PRODUCT NAME (MODEL)	SERIAL ADDRESS (DECIMAL)
Sample: North silo	Yo-Yo	000

TO SET UP THE VESSELS IN THE ORB

1. Log in to the ORB normally using a web browser.
User Login = Admin
Password = Admin
2. Scan for devices
 - a. Go to the NETWORKING tab
 - b. Click Set Up Serial Ports
 - c. Choose the Port that corresponds with the wiring of the ORB, click Configure
 - d. Choose the setting that matches the jumper setting (RS-485/MODBUS or KM/RS-422), click Update
 - e. Choose Manually Add Devices
 - f. Locate each serial address block (reference record table if required), click SCAN
 - g. Click continue, repeat until all devices have been successfully added. The ORB is now ready to begin taking readings.
3. A company administrator should be set up, as well as, any additional user profiles. See Using the ORB, Section VII for detailed instructions.

VII. USING THE ORB

TO SET COMPANY NAME AND LOGO

Choose ADMINISTRATION TAB/SET COMPANY NAME

1. Enter your company name and location
2. To add your company logo
 - a. Click Browse and find the file on your computer
 - b. Click the Use logo box
 - c. Click Update
3. Your name will now appear in the middle of the title bar, with the location underneath; the logo will be updated on the left side of the screen. The ORB, iLevel logo will remain

TO UPDATE OR CHANGE THE TIME OF THE ORB

Choose ADMINISTRATION TAB/SET TIME AND DATE

1. User must have Write permission to make changes to this screen
2. Select the region of the units current location
3. Click Submit

TO ADD ADDITIONAL DEVICES

After the ORB has initially been set up, choose NETWORKING TAB/SET UP SERIAL PORTS

1. Choose the Port that corresponds with the wiring of the ORB, click Configure

2. Choose the setting that matches the jumper setting (RS-485/MODBUS or KM/RS-422), click Update
3. Choose Manually Add Devices
4. Locate each serial address block (reference record table if required), click SCAN
5. Click continue. Repeat until all devices have been successfully added

TO EDIT THE SETTINGS OF EACH INDIVIDUAL VESSEL

Click the hyperlink above the image (See screen shot)

1. Update the following fields, as needed
 - a. Vessel Identifier
 - b. Vessel contents (Optional)
 - c. Color, shown on the main home screen of the ORB
 - d. Vessel shape
 - e. Maximum Capacity
 - f. Minimum Capacity
2. Click Update



TO SET A STRAPPING TABLE

Click the hyperlink above the image

1. Choose Edit Strapping Table
2. Insert Input data; uncorrected data from the device, customer specified
3. Insert Output data; corrected data from the device, customer specified
4. Click Update

This is an advanced feature of the ORB set up. It is often used when a user wishes to set the tank parameters in a particular way when determining levels.

TO SET ALARMS ON EACH VESSEL

Choose MANAGEMENT TAB\MANAGE ALARMS

1. Choose Manage Alarms
2. Click on the vessel that needs adjusted
3. Update fields as required
 - a. Trigger – define
 - b. Management type
 - c. Deadband
 - d. Display type
 - e. Title
 - f. Message Emailed
 - g. Email Addresses

4. Click Submit

NOTE: Email alarms require SMTP server set up

TO UPDATE OR ADJUST A VESSEL PARAMETER

Choose MANAGEMENT TAB/MANAGE DEVICES

1. Choose Manage Devices
2. Click on the vessel that needs adjusted
3. Click on parameter to change
4. Update settings as required
5. Click Update

TO UPDATE OR ADD USER IDS TO HAVE ACCESS TO THE ORB OR THE PERMISSIONS FOR EACH

Choose MANAGEMENT TAB/MANAGE PERSONNEL

1. Manage Users to create, edit or delete accounts
 - a. Fill in all fields to create an account
 - b. Select which vessels each user should have access to in the ORB
2. Manage Roles to create, edit or delete permission roles
 - a. Select appropriate access for each role for the ORB
 - b. Create a new role

TO MANAGE OR CREATE REPORTS

Choose MANAGEMENT TAB/MANAGE REPORTS

1. To see a report
 - a. Click on the report name
 - b. Add email address(es) where the report should be sent
 - c. Click submit
2. To create a new report
 - a. Click Add New Report
 - b. Create Title
 - c. Add Devices
 - d. Set the desired schedule
 - e. Add email address(es) where the report should be sent
 - f. Click submit

VIII. TROUBLESHOOTING

PROBLEM	POSSIBLE CAUSE	SOLUTION
Power On LED is off	Power Switch Off	Turn power On
10/100 Light On	10M bit connection	No problem
	Network cable not connected	Connect Network cable
Device Not Displayed on Main page	Page not setup to display all devices	Click edit View and update view, adding devices
An action is greyed out	Permission not setup	Administrator must manage users and roles to give the permission required.
No communication to Devices	Jumpers set incorrectly on ORB PCB	Setup jumpers per page 8, 9
	Wiring incorrect	Correct wiring per page 8, 9
	Com port not setup correctly	Click setup serial ports and correctly setup the serial port being used
	Broken serial cable	Do a continuity check or serial cable
	Device power off	Check power on each device
	Damaged ORB serial port	Login as an Admin, click setup serial ports and run the loop back test. See Figure 4 for wiring of loopback
Unable to connect to ORB	120 Ω End of Line Resistor not installed for Modbus	See wiring per page 9
	Incorrectly set IP address	Short pins 2 and 3 of the service DB9 serial port during a power cycle to set the IP address back to 192.168.1.170

Figure 4. Wiring for Loop Back Tests

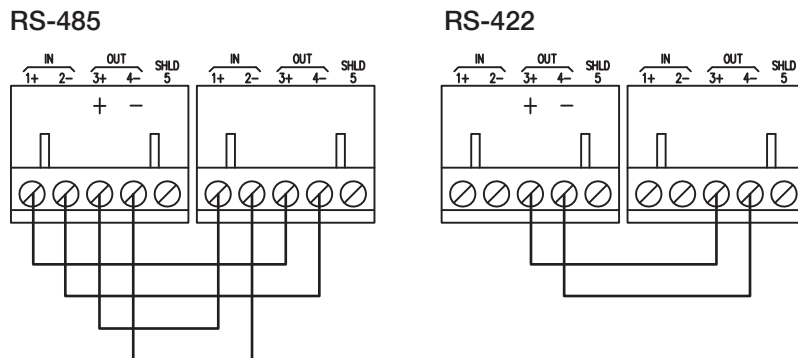

IX. DIMENSIONAL DRAWINGS

NEMA 4X Fiberglass Enclosures

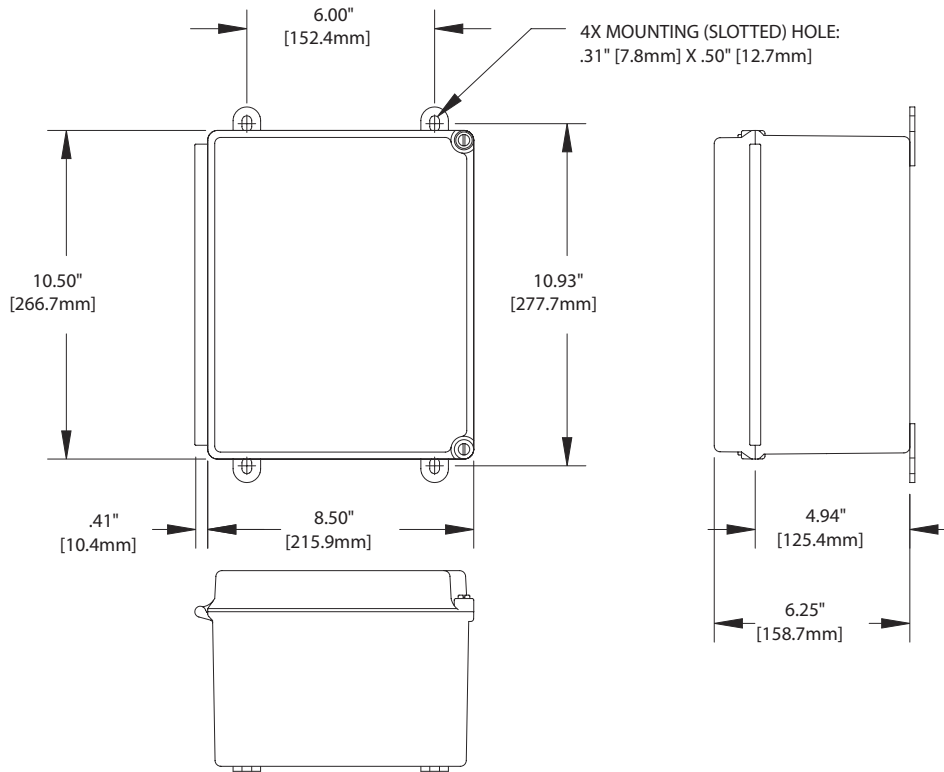

ORB Bracket Assembly

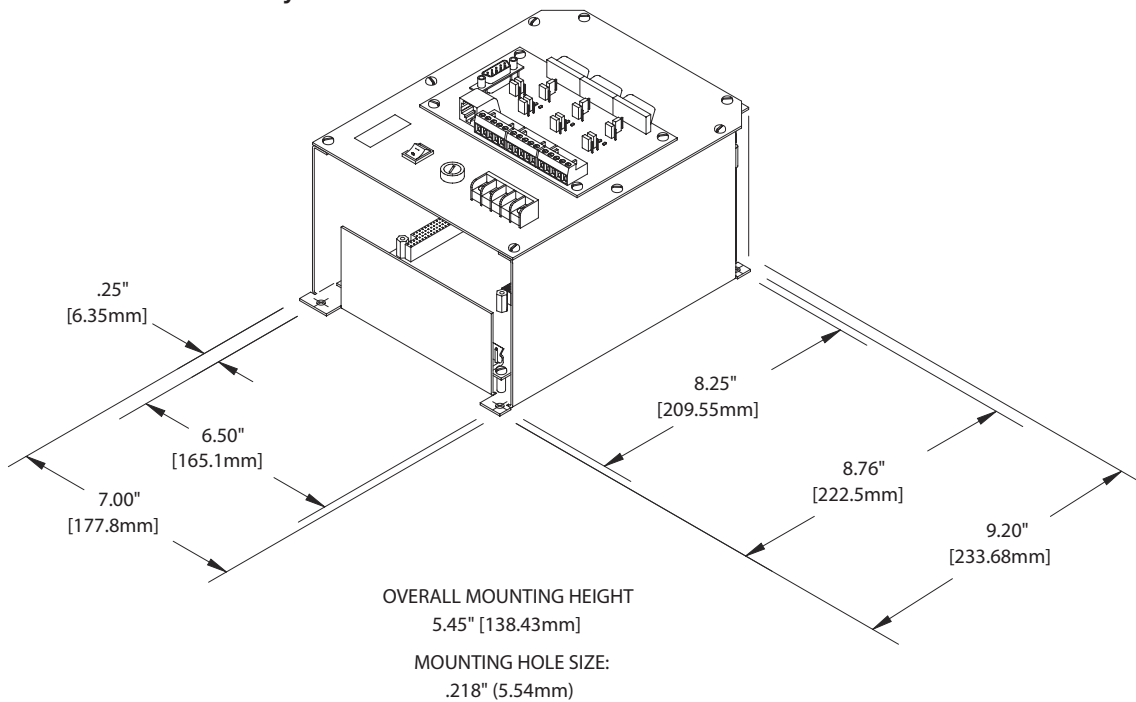

Notes:

Notes:



150 Venture Boulevard
Spartanburg, SC 29306
Tel: (800) 426-9010
Tel: (864) 574-2763 [Local]
Fax: (864) 574-8063
sales@kistlermorse.com
www.kistlermorse.com

venture
MEASUREMENT

2013 All rights reserved.
All data subject to change without notice.

97-1167-01 Rev. J