



ultra-wave™

Non-contact ultrasonic level measuring device provides continuous measurement and monitoring of levels in multiple vessels containing bulk solids or liquids.

.....
TECHNICAL SPECIFICATIONS



The ultra-wave™ Ultrasonic Level System can monitor vessels with up to 16 vessels with transducers of various frequencies, and vessels of different heights and shapes. It is compatible with Kistler-Morse® Sonocell® and ultra-cell™ transducers as well as transducers from other manufacturers, making it unsurpassed in capabilities. The system can accurately measure the level of many different materials like powders, solids, liquids and slurries. The range of Kistler-Morse® sensors allows you to read levels from 1 foot to beyond 100 feet in solids. The ultra-cell™ transducer has an extremely narrow beam angle, allowing it to be used in challenging applications. Additionally, the same unit does open channel flow and differential level measurements.

ORB-enabled™

Next generation communications interface.

Quick Config

Adjusts systems parameters and pre-calibrates unit without special software.

Modular Design

Configurable for number of sensors, relays, point level inputs, current loops, and PLC interfaces.

Multiple Functions In One Unit

Mix level, flow and DLD functions, different distance ranges, and solid as well as liquid applications.

Continuous Non-Contact Level Measurement

No contamination of material, no lost parts or cables, no material build-up on sensing face.

Sentry DSP™

Provides stable and accurate reading under process conditions.

Built-in Optically Isolated Serial Port

Versatile interfacing for data collection, servicing and building large multi-vessel communications systems.

NEMA-4X Enclosure

FRP or optional stainless steel offers the right protection for your environment.

HOW TO ORDER

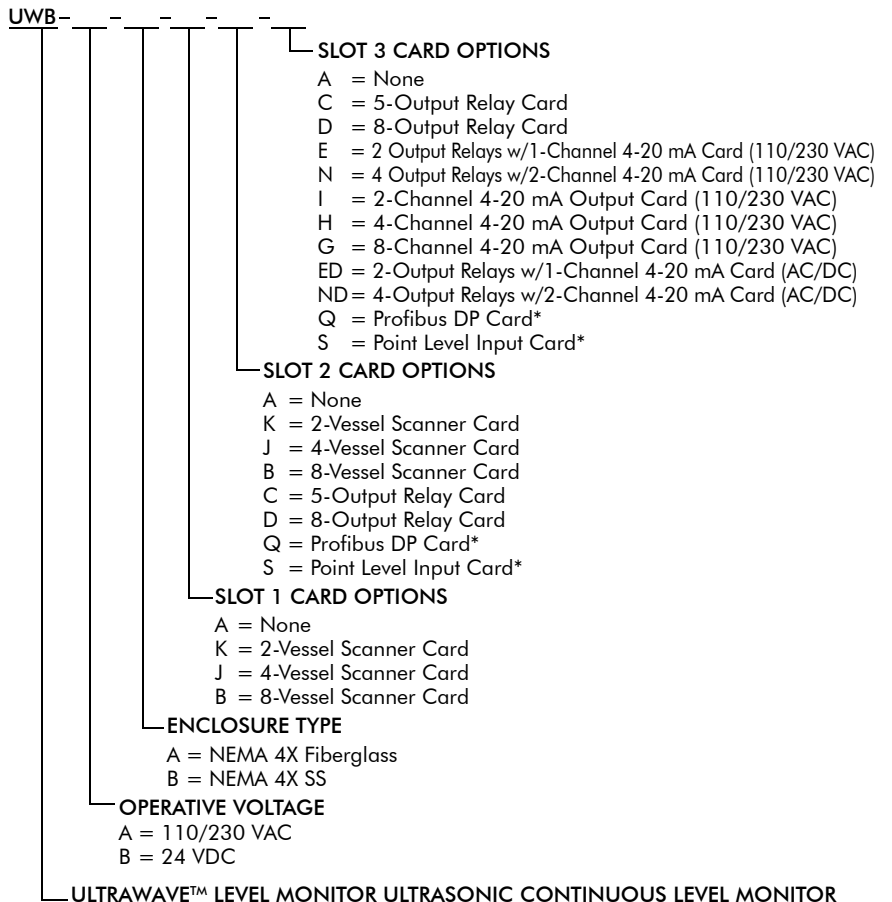

* Not CE approved.

SPECIFICATIONS

FUNCTIONAL SPECS

Operating Power	110/230 VAC (+/- 10%) 50/60 Hz or 24 VDC
Power Requirement	20 VA
Operating Temperature	-5° to 122° F (-20° to -50° C)
PERFORMANCE	
Transducer Compatibility	Frequencies from 10 KHz to 45 KHz
Memory	Non-volatile RAM, common isolation parameter storage
Relay Output	Form "C" SPDT, programmable, 10 A 110 VAC, 8 A 230 VAC non-inductive, 10 A 30 VDC; available as plug in modules of 2, 4, 5 and 8 relays each 4-20 mA option: Isolated 600 ohms maximum or externally powered to 1000 ohms, 12 bit resolution; available as plug in modules of 2, 4, and 8 outputs with common isolation; must be installed in third option slot Combi-Card option: One combi-card per unit; combinations are 2 relays, 1 current; or 4 relays, 2 currents
PHYSICAL	
Enclosures	NEMA 4X fiberglass reinforced polyester (FRP) or NEMA 4X Stainless Steel
Display	Large, back lit alphanumeric liquid crystal, two lines of 16 characters, user programmable IDs, selectable bar graph display or engineering units formats
APPROVALS	
	CE

DIMENSIONS

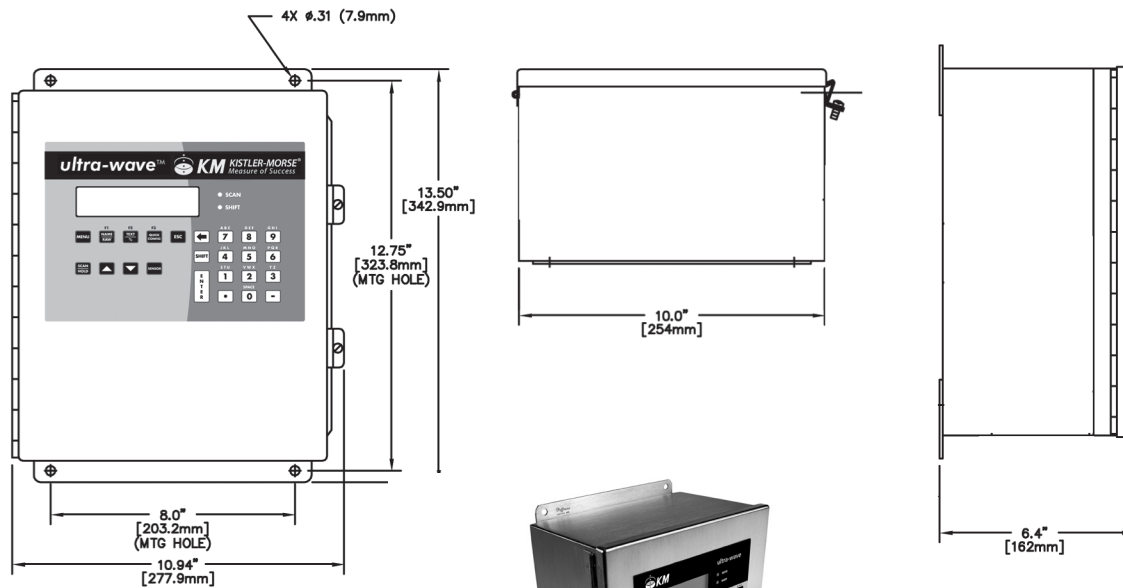

Optional Stainless Steel Enclosure

TRANSDUCERS

The Sonocell™ and ultra-cell™ transducers are components of the ultra-wave™. Kistler-Morse transducers are designed to perform in a wide range of environments, including caustics and other demanding conditions. Kistler-Morse will design your system solution to include the appropriate transducer for your specific application and environment.

FEATURES & BENEFITS

Versatility

- Available in frequencies of 14, 22, 24 and 43 kHz to fit a variety of materials and distances.

Accuracy

- 1% of rated span in approved bulk solids applications
- 0.25% of rated span in approved liquid applications.

APPROVALS

Hardous Location

FM; S Class I, II, III; Division I, Groups C, D, E, F and G; T5



**SC14PT
PVC Sensor**



**UC24PP
PVC Sensor**



**SC43SS
Stainless Steel Sensor**



**SC43TF
Teflon® Sensor**

TRANSDUCER SPECIFICATIONS

	Nominal Range Liquids	Nominal Range Solids	Minimum Range	Temperature Range	Weight	Frequency	Beam Angle
SC43PT	25' (7.6 m)	15'+(4.6 m)	12" (305 mm)	-40° to 180° F (-40° to 82° C)	1.2 lbs (0.5 kg)	43 kHz	12° included
SC43PT2	25' (7.6 m)	15'+(4.6 m)	12" (305 mm)	-40° to 180° F (-40° to 82° C)	1.2 lbs (0.5 kg)	43 kHz	12° included
SC43ST	25' (7.6 m)	15'+(4.6 m)	12" (305 mm)	-40° to 230° F (-40° to 110° C)	1.2 lbs (0.5 kg)	43 kHz	12° included
SC43SS	25' (7.6 m)	15'+(4.6 m)	12" (305 mm)	-40° to 230° F (-40° to 110° C)	1.2 lbs (0.5 kg)	43 kHz	12° included
SC43TF	25' (7.6 m)	Not applicable	12" (305 mm)	-40° to 160° F (-40° to 71° C)	7.2 lbs (3.3 kg)	43 kHz	12° included
SC22PT	50' (15.2 m)	30'+(9.2 m)	24" (610 mm)	-40° to 180° F (-40° to 82° C)	3.1 lbs (1.4 kg)	22 kHz	12° included
SC22ST	50' (15.2 m)	30'+(9.2 m)	24" (610 mm)	-40° to 230° F (-40° to 110° C)	6.0 lbs (2.7 kg)	22 kHz	12° included
SC22TF	50' (15.2 m)	Not applicable	24" (610 mm)	-40° to 160° F (-40° to 71° C)	7.3 lbs (3.3 kg)	22 kHz	12° included
UC24	100' (30.5 m)	50' grains 100' plastics	24" (610 mm)	-40° to 160° F (-40° to 71° C)	13.0 lbs (5.9kg)	24 kHz	5° included
SC14PT	125' (38.1 m)	100'+ (30.5 m)	36" (914 mm)	-40° to 180° F (-40° to 82° C)	5.75 lbs (2.6 kg)	14 kHz	12° included

TRANSDUCER MOUNTING DIMENSIONS

	A	B
SC43PT	5.2" (132.1 mm)	2.3" (58.41 mm)
SC43PT2	5.2" (132.1 mm)	2" NPT Fitting
SC43SS & SC43ST	5.5" (139.7 mm)	2.5" (63.5 mm)
SC43TF	5.3" (134.8 mm)	Standard ANSI Flanges
SC22PT	6.9" (175 mm)	4.2" (107 mm)
SC22TF	7.4" (188 mm)	Standard ANSI Flanges
SC22ST	6.8" (172.7 mm)	4.7" (119.3 mm)
UC24PP	18.3" (463.6 mm)	7.12" (180.8 mm)
SC14PT	9.2" (233.7 mm)	5.5" (139.7 mm)

